

User Manual

# GETTING STARTED? EASY.



ZCI66278XA

EN User Manual  
Cooker

# ZANUSSI

## SAFETY INFORMATION

---

Before the installation and use of the appliance, carefully read the supplied instructions. The manufacturer is not responsible for any injuries or damages that are the result of incorrect installation or usage. Always keep the instructions in a safe and accessible location for future reference.

## **CHILDREN AND VULNERABLE PEOPLE SAFETY**



### **WARNING!**

Risk of suffocation, injury or permanent disability.

- This appliance can be used by children aged from 8 years and above and persons with reduced physical, sensory or mental capabilities or lack of experience and knowledge if they have been given supervision or instruction concerning the use of the appliance in a safe way and understand the hazards involved.
- Do not let children play with the appliance.
- Keep all packaging away from children and dispose of it appropriately.
- Keep children and pets away from the appliance when it operates or when it cools down. Accessible parts are hot.
- If the appliance has a child safety device, this should be activated.
- Children shall not carry out cleaning and user maintenance of the appliance without supervision.

## **GENERAL SAFETY**

- Only a qualified person must install this appliance and replace the cable.
- This appliance must be connected to the mains with a H05VV-F type cable to withstand the temperature of the rear panel.
- This appliance is intended for use up to an altitude of 2000 m above sea level.
- This appliance is not intended to be used on a ships, boats or vessels.
- Do not install the appliance behind a decorative door in order to avoid overheating.

- Do not install the appliance on a platform.
- Do not operate the appliance by means of an external timer or separate remote-control system.
- **WARNING:** Unattended cooking on a hob with fat or oil can be dangerous and may result in fire.
- **NEVER** try to extinguish a fire with water, but switch off the appliance and then cover flame e.g. with a lid or a fire blanket.
- **CAUTION:** The cooking process has to be supervised. A short term cooking process has to be supervised continuously.
- **WARNING:** Danger of fire: Do not store items on the cooking surfaces.
- Do not use a steam cleaner to clean the appliance.
- Do not use harsh abrasive cleaners or sharp metal scrapers to clean the glass door or the glass of hinged lids of the hob since they can scratch the surface, which may result in shattering of the glass.
- Metallic objects such as knives, forks, spoons and lids should not be placed on the hob surface since they can get hot.
- If the glass ceramic surface / glass surface is cracked, switch off the appliance to avoid the possibility of electric shock.
- After use, switch off the hob element by its control and do not rely on the pan detector.
- **WARNING:** The appliance and its accessible parts become hot during use. Care should be taken to avoid touching heating elements. Children less than 8 years of age shall be kept away unless continuously supervised.
- Always use oven gloves to remove or put in accessories or ovenware.
- Before maintenance cut the power supply.
- Ensure that the appliance is switched off before replacing the lamp to avoid the possibility of electric shock.
- If the mains power supply cable is damaged, it must be replaced by the manufacturer, its Authorised Service Centre or similarly qualified persons to avoid an electrical hazard.
- To remove the shelf supports first pull the front of the shelf support and then the rear end away from the side walls. Install the shelf supports in the opposite sequence.

- The means for disconnection must be incorporated in the fixed wiring in accordance with the wiring rules.
- **WARNING:** Use only hob guards designed by the manufacturer of the cooking appliance or indicated by the manufacturer of the appliance in the instructions for use as suitable or hob guards incorporated in the appliance. The use of inappropriate guards can cause accidents.

## SAFETY INSTRUCTIONS

---

### INSTALLATION



**WARNING!** Only a qualified person must install this appliance.

- Remove all the packaging.
  - Do not install or use a damaged appliance.
  - Follow the installation instruction supplied with the appliance.
  - Always take care when moving the appliance as it is heavy. Always use safety gloves and enclosed footwear.
  - Do not pull the appliance by the handle.
  - The kitchen cabinet and the recess must have suitable dimensions.
  - Keep the minimum distance from the other appliances and units.
  - Make sure that the appliance is installed below and adjacent safe structures.
  - Parts of the appliance carry current. Close the appliance with furniture to prevent touching the dangerous parts.
  - The sides of the appliance must stay adjacent to appliances or to units with the same height.
  - Do not install the appliance adjacent to a door or under a window. This prevents hot cookware to fall from the appliance when the door or the window is opened.
  - Make sure to install a stabilizing means in order to prevent tipping of the appliance. Refer to Installation chapter.
- Always use a correctly installed shockproof socket.
  - Do not use multi-plug adapters and extension cables.
  - Do not let mains cables touch or come near the appliance door, especially when the door is hot.
  - The shock protection of live and insulated parts must be fastened in such a way that it cannot be removed without tools.
  - Connect the mains plug to the mains socket only at the end of the installation. Make sure that there is access to the mains plug after the installation.
  - If the mains socket is loose, do not connect the mains plug.
  - Do not pull the mains cable to disconnect the appliance. Always pull the mains plug.
  - Use only correct isolation devices: line protecting cut-outs, fuses (screw type fuses removed from the holder), earth leakage trips and contactors.
  - The electrical installation must have an isolation device which lets you disconnect the appliance from the mains at all poles. The isolation device must have a contact opening width of minimum 3 mm.
  - Fully close the appliance door, before you connect the mains plug to the mains socket.

### ELECTRICAL CONNECTION



**WARNING!** Risk of fire and electrical shock.

- All electrical connections should be made by a qualified electrician.
  - The appliance must be earthed.
  - Make sure that the parameters on the rating plate are compatible with the electrical ratings of the mains power supply.
- This appliance is for household use only.
  - Do not change the specification of this appliance.
  - Make sure that the ventilation openings are not blocked.
  - Do not let the appliance stay unattended during operation.
  - Deactivate the appliance after each use.

### USE



**WARNING!** Risk of injury and burns. Risk of electrical shock.

- Be careful when you open the appliance door while the appliance is in operation. Hot air can release.
- Do not operate the appliance with wet hands or when it has contact with water.
- Do not use the appliance as a work surface or as a storage surface.
- Users with a pacemaker must keep a distance of minimum 30 cm from the induction cooking zones when the appliance is in operation.
- Cookware made of cast iron, aluminium or with a damaged bottom can cause scratches. Always lift these objects up when you have to move them on the cooking surface.
- This appliance is for cooking purposes only. It must not be used for other purposes, for example room heating.



**WARNING!** Risk of fire and explosion

- Fats and oil when heated can release flammable vapours. Keep flames or heated objects away from fats and oils when you cook with them.
- The vapours that very hot oil releases can cause spontaneous combustion.
- Used oil, that can contain food remnants, can cause fire at a lower temperature than oil used for the first time.
- Do not put flammable products or items that are wet with flammable products in, near or on the appliance.
- Do not let sparks or open flames to come in contact with the appliance when you open the door.
- Open the appliance door carefully. The use of ingredients with alcohol can cause a mixture of alcohol and air.



**WARNING!** Risk of damage to the appliance.

- To prevent damage or discoloration to the enamel:
  - do not put ovenware or other objects in the appliance directly on the bottom.
  - do not put water directly into the hot appliance.
  - do not keep moist dishes and food in the appliance after you finish the cooking.
  - be careful when you remove or install the accessories.
- Discoloration of the enamel or stainless steel has no effect on the performance of the appliance.
- Use a deep pan for moist cakes. Fruit juices cause stains that can be permanent.
- Do not keep hot cookware on the control panel.
- Do not let cookware boil dry.
- Be careful not to let objects or cookware fall on the appliance. The surface can be damaged.
- Do not activate the cooking zones with empty cookware or without cookware.
- Do not put aluminium foil on the appliance or directly on the bottom of the appliance.

## CARE AND CLEANING



**WARNING!** Risk of injury, fire, or damage to the appliance.

- Before maintenance, deactivate the appliance. Disconnect the mains plug from the mains socket.
- Make sure the appliance is cold. There is the risk that the glass panels can break.
- Replace immediately the door glass panels when they are damaged. Contact the Authorised Service Centre.
- Be careful when you remove the door from the appliance. The door is heavy!
- Fat and food remaining in the appliance can cause fire.
- Clean regularly the appliance to prevent the deterioration of the surface material.
- Make sure the cavity and the door are wiped dry after each use. Steam produced during the operation of the appliance condensates on cavity walls and can cause corrosion. To decrease the condensation operate the appliance for 10 minutes before cooking.
- Clean the appliance with a moist soft cloth. Only use neutral detergents. Do not use any abrasive products, abrasive cleaning pads, solvents or metal objects.
- If you use an oven spray, obey the safety instructions on the packaging.
- Do not clean the catalytic enamel (if applicable) with any kind of detergent.

## INTERNAL LIGHT

- The type of light bulb or halogen lamp used for this appliance is only for household appliances. Do not use it for house lighting.



**WARNING!** Risk of electrical shock.

- Before replacing the lamp, disconnect the appliance from the power supply.
- Only use lamps with the same specifications.

## DISPOSAL



**WARNING!** Risk of injury or suffocation.

- Disconnect the appliance from the mains supply.
- Cut off the mains electrical cable close to the appliance and dispose of it.

- Remove the door catch to prevent children or pets from becoming trapped in the appliance.

## SERVICE

- To repair the appliance contact an Authorised Service Centre.
- Use original spare parts only.

# PRODUCT DESCRIPTION

## GENERAL OVERVIEW

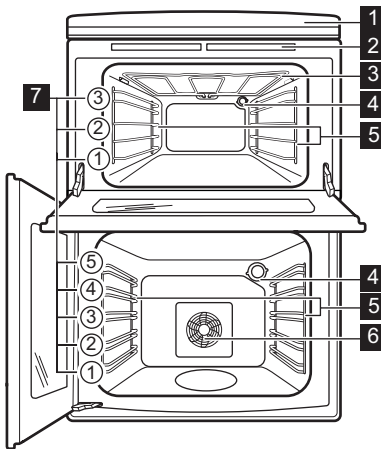

- 1 Control panel and hob
- 2 Air vents for the cooling fan
- 3 Heating element
- 4 Lamp
- 5 Shelf support, removable
- 6 Fan
- 7 Shelf positions

## COOKING SURFACE LAYOUT

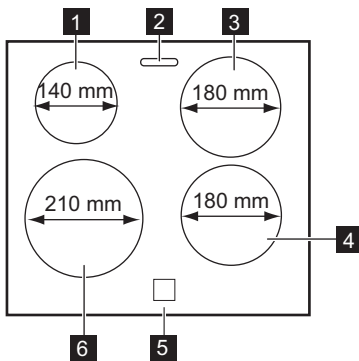

- 1 Induction cooking zone 1400 W with the Power function 2500 W
- 2 Steam outlet - number and position depend on the model
- 3 Induction cooking zone 1800 W with the Power function 2800 W
- 4 Induction cooking zone 1800 W with the Power function 2800 W
- 5 Control panel
- 6 Induction cooking zone 2300 W with the Power function 3600 W

## COOKER CONTROL PANEL

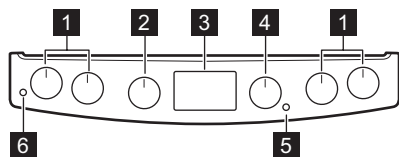

- 1 Knobs for the hob
- 2 Knob for the top oven functions
- 3 Electronic programmer
- 4 Knob for the main oven functions
- 5 Temperature indicator / symbol for the main oven
- 6 Temperature indicator / symbol for the top oven

## ACCESSORIES

- **Wire shelf**  
For cookware, cake tins, roasts.
- **Grill- / Roasting pan**  
To bake and roast or as pan to collect fat.
- **Trivet**

For roasting and grilling.

-  Use the trivet only with the Grill- / roasting pan.

## BEFORE FIRST USE



**WARNING!** Refer to Safety chapters.

### INITIAL CLEANING

Remove all accessories and removable shelf supports from the appliance.



Refer to "Care and cleaning" chapter.

Clean the appliance and the accessories before first use.

Put the accessories and the removable shelf supports back to their initial position.



### USING THE SENSOR FIELDS

To activate a function touch and hold the selected symbol on the display for minimum 1 second.

### SETTING AND CHANGING THE TIME

You must set the time before you operate the oven.

When you connect the appliance to the electrical supply or after a power cut,  flashes.

Press the  or  to set the correct time. After approximately 5 seconds, the flashing stops and the display shows the time of day.

To change the time, press  again and again until  starts to flash.

### PREHEATING

Preheat the empty appliance before first use.



Preheat the two ovens. Heat up one oven at a time.

1. Set the maximum temperature.
2. Let the appliance operate for 1 hour.
3. Set the function .
4. Let the appliance operate for 15 minutes.

Accessories can become hotter than usual. The appliance can emit an odour and smoke. This is normal. Make sure that the airflow is sufficient.

## HOB - DAILY USE



**WARNING!** Refer to Safety chapters.

## HOB CONTROL PANEL

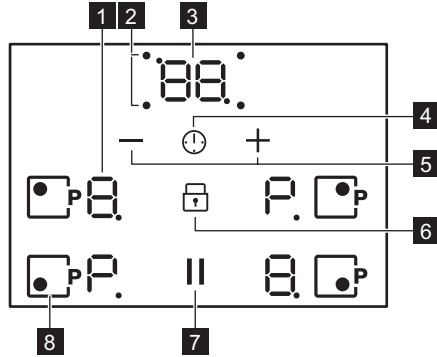











Use the sensor fields to operate the appliance. The displays, indicators and sounds tell which functions operate.

|   | Sensor field | Function                          | Comment                                  |
|---|--------------|-----------------------------------|--|
| 1 | -            | Heat setting display              | To show the heat setting.                |
| 2 | -            | Timer indicators of cooking zones | To show for which zone you set the time. |
| 3 | -            | Timer display                     | To show the time in minutes.             |
| 4 | 🕒            | -                                 | To select the cooking zone.              |
| 5 | + / -        | -                                 | To increase or decrease the time.        |
| 6 | 🔒            | Lock / Child Safety Device        | To lock / unlock the control panel.      |
| 7 | ⏸            | Pause                             | To activate and deactivate the function. |
| 8 | 🔥P           | PowerBoost                        | To activate and deactivate the function. |

## HEAT SETTING DISPLAYS



| Display       | Description  |
|---------------|--|
| 0             | The cooking zone is deactivated.   |
| 1 - 9 / 2 - 6 | The cooking zone operates.<br>The dot means a change by half of a heating level. |



| Display   | Description  |
|---|--|
|    | Pause operates.  |
|    | Automatic Heat Up operates.  |
|    | PowerBoost operates.   |
|  + digit   | There is a malfunction.  |
|  /  /  | OptiHeat Control (3 step Residual heat indicator): continue cooking / keep warm / residual heat. |
|    | Lock / Child Safety Device operates.   |
|    | Incorrect or too small cookware or no cookware on the cooking zone.                              |
|    | Automatic Switch Off operates.   |

### OPTIHEAT CONTROL (3 STEP RESIDUAL HEAT INDICATOR)



**WARNING!**  /  /  There is a risk of burns from residual heat. The indicators show the level of the residual heat for the cooking zones you are currently using. The indicators may also come on for the neighbouring cooking zones even if you are not using them.

The induction cooking zones produce the heat necessary for the cooking process directly in the bottom of the cookware. The glass ceramic is heated by the heat of the cookware.



### THE HEAT SETTING

To set or change the heat setting turn the knob to the correct heat setting. To deactivate turn the knob to off position **0**.

### AUTOMATIC SWITCH OFF

**The function deactivates the hob automatically if:**

- all cooking zones are deactivated,
- you do not set the heat setting after you activate the hob,
- you spill something or put something on the control panel for more than 10 seconds (a pan, a cloth, etc.). An acoustic signal sounds and the hob deactivates. Remove the object or clean the control panel.

- the hob gets too hot (e.g. when a saucepan boils dry). Let the cooking zone cool down before you use the hob again.
- you use incorrect cookware. The symbol  comes on and the cooking zone deactivates automatically after 2 minutes.
- you do not deactivate a cooking zone or change the heat setting. After some time  comes on and the hob deactivates.

**The relation between the heat setting and the time after which the hob deactivates:**

| Heat setting  | The hob deactivates after |
|---|---------------------------|
|  , 1 - 2 | 6 hours                   |
| 3 - 4   | 5 hours                   |
| 5   | 4 hours                   |
| 6 - 9   | 1.5 hour                  |

### AUTOMATIC HEAT UP

If you activate this function you can get a necessary heat setting in a shorter time. The function sets the highest heat setting for some time and then decreases to the correct heat setting.



To activate the function the cooking zone must be cold.

### To activate the function for a cooking zone:

turn the knob for a cooking zone to position **A**.  comes on in the display. Immediately set the correct heat setting.

**To deactivate the function:** turn the knob to the off position.

### POWERBOOST

This function makes more power available to the induction cooking zones. The function can be activated for the induction cooking zone only for a limited period of time. After this time the induction cooking zone automatically sets back to the highest heat setting.

### To activate the function for a cooking zone:

touch   comes on.

**To deactivate the function:** change the heat setting.

### TIMER

#### Count Down Timer

You can use this function to set how long the cooking zone should operate for a single cooking session.



First set the heat setting for the cooking zone then set the function.





**To set the cooking zone:** touch  again and again until the indicator of a necessary cooking zone comes on.

**To activate the function:** touch  of the timer to set the time (00 - 99 minutes). When the indicator of the cooking zone starts to flash slowly the time counts down.

**To see the remaining time:** set the cooking zone with . The indicator of the cooking zone starts to flash quickly. The display shows the remaining time.

**To change the time:** set the cooking zone with

. Touch  or .

**To deactivate the function:** set the cooking zone with  and touch . The remaining time counts back to 00. The indicator of the cooking zone goes out. To deactivate the function you can also touch  and  at the same time.



 When the time comes to an end, the sound operates and 00 flashes. The cooking zone deactivates.

**To stop the sound:** touch .

### CountUp Timer (The count up timer)



You can use this function to monitor how long the cooking zone operates.

**To set the cooking zone:** touch  again and again until the indicator of a necessary cooking zone comes on.

**To activate the function:** touch  of the timer.  comes on. When the indicator of the cooking zone starts to flash slowly the time counts up. The display switches between  and counted time (minutes).



### To see how long the cooking zone operates:

set the cooking zone with . The indicator of the cooking zone starts to flash quickly. The display shows how long the zone operates.

**To deactivate the function:** set the cooking zone with  and touch  or . The indicator of the cooking zone goes out.

### Minute Minder

You can use this function as a **Minute Minder** when the hob is activated and the cooking zones do not operate. The heat setting display shows .

**To activate the function:** touch . Touch  or  of the timer to set the time. Cooking zones display deactivates automatically after 10 seconds. When the time comes to an end, the sound operates and **00** flashes.

**To stop the sound:** touch .

**To deactivate the function:** activate for a short time and deactivate left front cooking zone.

 The function has no effect on the operation of the cooking zones.

### PAUSE

This function sets all cooking zones that operate to the lowest heat setting.

The function does not stop the timer functions.

Touch  to activate the function.

 comes on. The heat setting is lowered to 1.



To deactivate the function, touch . The previous heat setting comes on.

 If you change the heat setting, the function stops and the display shows the new heat setting.

## LOCK

You can lock the sensors on the hob while cooking zones operate.

### Set the heat setting first.

**To activate the function:** touch .  comes on for 4 seconds. The Timer stays on.





**To deactivate the function:** touch . The previous heat setting comes on.









When you deactivate the hob, you also deactivate this function.

## CHILD SAFETY DEVICE





This function prevents an accidental operation of the hob.

**To activate the function:** the hob must be deactivated. Touch  for 4 seconds until  flashes. Touch .  comes on for 4 seconds.

**To deactivate the function:** the hob must be deactivated. Touch  for 4 seconds until  flashes. Touch .  comes on for 4 seconds.

**To override the function for only one cooking time:** activate a cooking zone.  comes on. Touch  for 4 seconds until  comes on for all zones. **Set the heat setting in 4 seconds.** You can operate the hob. When you deactivate the appliance the function operates again.

## OFFSOUND CONTROL (DEACTIVATION AND ACTIVATION OF THE SOUNDS)

Deactivate the hob. Touch  for 3 seconds. Touch  for 3 seconds.  or  comes on. Touch  of the timer to choose one of the following:

-  - the sounds are off

-  - the sounds are on.

To confirm your selection wait until the hob deactivates automatically.

When the function is set to  you can hear the sounds only when:

- Minute Minder comes down
- Count Down Timer comes down
- you put something on the control panel.

## POWER MANAGEMENT FUNCTION

- All cooking zones are connected as on the illustration.
- The hob and both ovens are connected to one phase.
- The phase has a maximum electricity load.
- The function divides the power within the appliance. The oven is more important than the hob.
- The function activates when the total electricity load in the appliance is exceeded.
- The function decreases the power on the cooking zones to prevent a circuit overload.
- The heat setting display of the reduced zones changes between two levels.

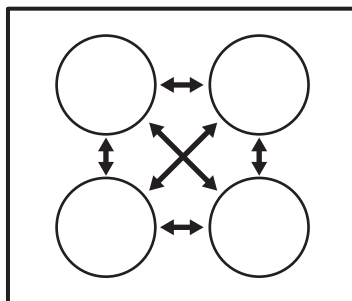

## HOB - HINTS AND TIPS



**WARNING!** Refer to Safety chapters.

## COOKWARE



For induction cooking zones a strong electro-magnetic field creates the heat in the cookware very quickly.



Use the induction cooking zones with correct cookware.

## Cookware material

- **correct:** cast iron, steel, enamelled steel, stainless steel, the bottom made of multi-layer (with correct mark from a manufacturer).
- **not correct:** aluminium, copper, brass, glass, ceramic, porcelain.

## Cookware is correct for an induction hob if:

- some water boils very quickly on a zone set to the highest heat setting.
- a magnet pulls on to the bottom of the cookware.



The bottom of the cookware must be as thick and flat as possible.

### Cookware dimensions

Induction cooking zones adapt to the dimension of the bottom of the cookware automatically to some limit.

The cooking zone efficiency is related to the diameter of the cookware. The cookware with a smaller diameter than the minimum receives only a part of the power generated by the cooking zone.

### MINIMUM COOKWARE DIAMETER

| Cooking zone | Cookware diameter (mm) |
|--------------|------------------------|
| Left rear    | 125 - 140              |
| Right rear   | 145 - 180              |
| Right front  | 145 - 180              |
| Left front   | 180 - 210              |

### THE NOISES DURING OPERATION

#### If you can hear:

- crack noise: cookware is made of different materials (sandwich construction).

- whistle sound: you use the cooking zone with high power level and the cookware is made of different materials (sandwich construction).
- humming: you use high power level.
- clicking: electric switching occurs.
- hissing, buzzing: the fan operates.

**The noises are normal and do not refer to hob malfunction.**

### ÖKO TIMER (ECO TIMER)

To save energy, the heater of the cooking zone deactivates before the count down timer sounds. The difference in the operation time depends on the heat setting level and the length of the cooking operation.

### EXAMPLES OF COOKING APPLICATIONS

The relation between the heat setting and the cooking zone consumption of power is not linear. When you increase the heat setting, it is not proportional to the increase of the cooking zone consumption of power. It means that the cooking zone with the medium heat setting uses less than a half of its power.



The data in the table is for guidance only.

| Heat setting | Use to:  | Time (min)   | Hints   |
|--------------|--|--------------|---|
| - 1          | Keep cooked food warm.   | as necessary | Put a lid on the cookware.  |
| 1 - 2.       | Hollandaise sauce, melt: butter, chocolate, gelatine.            | 5 - 25       | Mix from time to time.  |
| 1 - 2.       | Solidify: fluffy omelettes, baked eggs.                          | 10 - 40      | Cook with a lid on.   |
| 2 - 3.       | Simmer rice and milkbased dishes, heating up ready-cooked meals. | 25 - 50      | Add the minimum twice as much liquid as rice, mix milk dishes part procedure through. |
| 3 - 4.       | Steam vegetables, fish, meat.                                    | 20 - 45      | Add some tablespoons of liquid.   |
| 4 - 5.       | Steam potatoes.  | 20 - 60      | Use max. 1/4 l water for 750 g of potatoes.   |
| 4 - 5.       | Cook larger quantities of food, stews and soups.                 | 60 - 150     | Up to 3 l liquid plus ingredients.  |

| Heat setting  | Use to:  | Time (min)   | Hints                 |
|---|--|--------------|-----------------------|
| 5. - 7  | Gentle fry: escalope, veal cordon bleu, cutlets, rissoles, sausages, liver, roux, eggs, pancakes, doughnuts. | as necessary | Turn halfway through. |
| 7 - 8   | Heavy fry, hash browns, loin steaks, steaks.   | 5 - 15       | Turn halfway through. |
| 9   | Boil water, cook pasta, sear meat (goulash, pot roast), deep-fry chips.                                      |              |                       |
|  | Boil large quantities of water. Power function is activated.   |              |                       |

## HOB - CARE AND CLEANING



**WARNING!** Refer to Safety chapters.

### GENERAL INFORMATION

- Clean the hob after each use.
- Always use cookware with clean bottom.
- Scratches or dark stains on the surface have no effect on how the hob operates.
- Use a special cleaner applicable for the surface of the hob.
- Use a special scraper for the glass.

### CLEANING THE HOB

- **Remove immediately:** melted plastic, plastic foil, sugar and food with sugar. If not, the dirt

can cause damage to the hob. Take care to avoid burns. Put the special scraper on the glass surface at an acute angle and move the blade on the surface.

- **Remove when the hob is sufficiently cool:** limescale rings, water rings, fat stains, shiny metallic discoloration. Clean the hob with a moist cloth and non-abrasive detergent. After cleaning, wipe the hob dry with a soft cloth.
- **Remove shiny metallic discoloration:** use a solution of water with vinegar and clean the glass surface with a moist cloth.



## OVEN - DAILY USE





**WARNING!** Refer to Safety chapters.

### TOP OVEN FUNCTIONS

| Symbol  | Oven function | Application                                      |
|---|---------------|--|
| 0   | Off position  | The appliance is off.                            |
|  | Oven Lamp     | To activate the lamp without a cooking function. |

| Symbol   | Oven function        | Application  |
|--|----------------------|--|
| 100 - 250  | Conventional Cooking | To bake and roast food on one shelf position.  |
|  | Dual Circuit Grill   | To grill food items in medium quantities in the middle of the shelf. To make toasts. |
|  | Full Grill           | To grill flat food and to toast bread.   |

## MAIN OVEN FUNCTIONS

| Symbol   | Oven function | Application  |
|--|---------------|--|
| 0  | Off position  | The appliance is off.  |
|  | Oven Lamp     | To activate the lamp without a cooking function.   |
|  | Defrost       | This function can be used for defrosting frozen foods, such as vegetables and fruits. The defrosting time depends on the amount and size of the frozen food. |
| 100 - 250  | Thermaflow®   | To bake on up to three shelf positions at the same time and to dry food. Set the temperature 20 - 40 °C lower than for Conventional Cooking.                 |

## ACTIVATING AND DEACTIVATING THE TOP / MAIN OVEN



**It depends on the model if your appliance has knob symbols, indicators or lamps:**

- The indicator comes on when the oven heats up.
- The lamp comes on when the oven operates.
- The symbol shows whether the knob controls one of the cooking zones, the oven functions or the temperature.

1. Turn the knob for the top / main oven functions to select an oven function.
2. To deactivate the oven turn the knob for the top / main oven functions to the off position.

## COOLING FAN

When the oven operates, the cooling fan turns on automatically to keep the surfaces of the oven cool. If you turn off the oven, the cooling fan can continue to operate until the oven cools down.

## INSERTING THE OVEN ACCESSORIES

### Deep pan:

Push the deep pan between the guide bars of the shelf support.

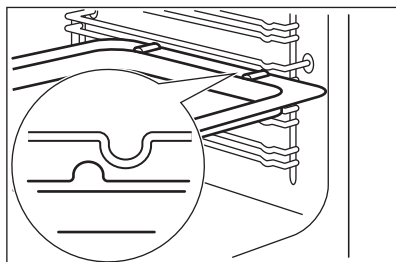

### Wire shelf and the deep pan together:

Push the deep pan between the guide bars of the shelf support and the wire shelf on the guide bars above.

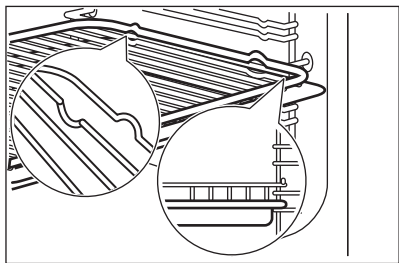

- All accessories have small indentations at the top of the right and left side to increase safety. The indentations are also anti-tip devices.
- The high rim around the shelf is a device which prevents cookware from slipping.

### TRIVET AND GRILL- / ROASTING PAN



**WARNING!** Be careful when you remove the accessories from a hot appliance. There is a risk of burns.

You can use the trivet to roast larger pieces of meat or poultry on one shelf position.

1. Put the trivet into the deep pan so that the supports of the wire shelf point up.

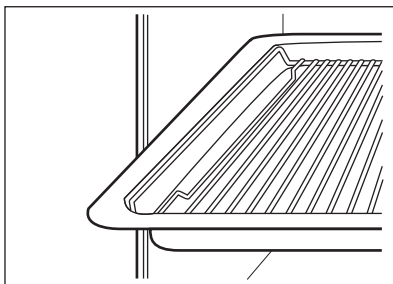

2. Put the deep pan into the oven on the necessary shelf position.  
You can use the trivet to grill flat dishes in large quantities and to toast.

1. Put the trivet into the deep pan so that the supports of the wire shelf point down.

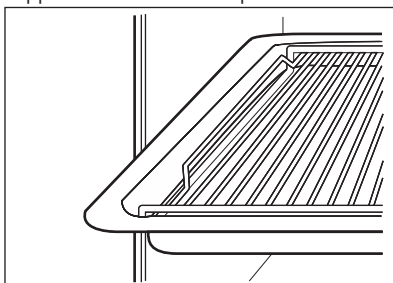

2. Put the deep pan into the oven on the necessary shelf position.

## OVEN - CLOCK FUNCTIONS

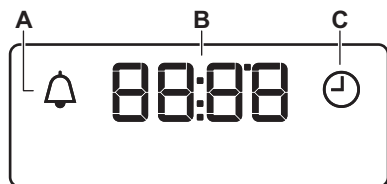

### DISPLAY







- A. Minute minder indicator
- B. Time display
- C. Time of day indicator

### BUTTONS

| Button | Function | Description      |
|--------|----------|------------------|
| —      | MINUS    | To set the time. |



| Button  | Function | Description              |
|---|----------|--------------------------|
|  | CLOCK    | To set a clock function. |
|  | PLUS     | To set the time.         |

### SETTING THE MINUTE MINDER

1. Press  again and again until  starts to flash.
2. Press  or  to set the necessary time. The Minute Minder starts automatically after 5 seconds.
3. When the set time ends, an acoustic signal sounds. Press any button to stop the acoustic signal.

4. Turn the knob for the oven functions to the off position.

### CANCELLING THE CLOCK FUNCTIONS

1. Press the  again and again until the necessary function indicator starts to flash.
  2. Press and hold .
- The clock function goes out after some seconds.

## OVEN - HINTS AND TIPS



**WARNING!** Refer to Safety chapters.



The temperature and baking times in the tables are guidelines only. They depend on the recipes and the quality and quantity of the ingredients used. Always preheat an empty oven at the temperature required for the food for 20 minutes before you start cooking.

### TOP OVEN

The top oven is the smaller of the two ovens. It has 3 shelf positions. Use it to cook smaller quantities of food. It gives especially good results when used to cook fruitcakes, sweets and savoury flants or quiche.

### MAIN OVEN

The main oven is particularly suitable for cooking larger quantities of food.

### BAKING

- Your oven may bake or roast differently to the appliance you had before. Adapt your usual settings such as temperature, cooking time and shelf position to the values in the tables.
- Use the lower temperature the first time.
- If you cannot find the settings for a special recipe, look for the similar one.
- You can extend baking times by 10 – 15 minutes if you bake cakes on more than one shelf position.
- Cakes and pastries at different heights do not always brown equally at first. If this occurs, do not change the temperature setting. The differences equalize during the baking procedure.
- Trays in the oven can twist during baking. When the trays become cold again, the distortions disappear.

### TIPS ON BAKING

| Baking results                                      | Possible cause                   | Remedy                         |
|---|----------------------------------|--------------------------------|
| The bottom of the cake is not browned sufficiently. | The shelf position is incorrect. | Put the cake on a lower shelf. |



| <b>Baking results</b>                               | <b>Possible cause</b>  | <b>Remedy</b>   |
|---|--|---|
| The cake sinks and becomes soggy, lumpy or streaky. | The oven temperature is too high.                                  | The next time you bake, set a slightly lower oven temperature.                                    |
| The cake sinks and becomes soggy, lumpy or streaky. | The baking time is too short.                                      | Set a longer baking time. <b>You cannot decrease baking times by setting higher temperatures.</b> |
| The cake sinks and becomes soggy, lumpy or streaky. | There is too much liquid in the mixture.                           | Use less liquid. Be careful with mixing times, especially if you use a mixing machine.            |
| The cake is too dry.                                | The oven temperature is too low.                                   | The next time you bake, set a higher oven temperature.  |
| The cake is too dry.                                | The baking time is too long.                                       | The next time you bake, set a shorter baking time.  |
| The cake browns unevenly.                           | The oven temperature is too high and the baking time is too short. | Set a lower oven temperature and a longer baking time.  |
| The cake browns unevenly.                           | The mixture is unevenly distributed.                               | Spread the mixture evenly on the baking tray.   |
| The cake is not ready in the baking time given.     | The oven temperature is too low.                                   | The next time you bake, set a slightly higher oven temperature.                                   |

### **CONVENTIONAL BAKING - TOP OVEN**

| <b>Food</b>              | <b>Temperature (°C)</b>             | <b>Time (min)</b> | <b>Shelf position</b> |
|--------------------------|-------------------------------------|-------------------|-----------------------|
| Biscuits                 | 170 - 190                           | 10 - 20           | 2                     |
| Bread                    | 200 - 220                           | 30 - 35           | 2                     |
| Bread rolls / buns       | 200 - 220                           | 10 - 15           | 2                     |
| Cakes: Victoria Sandwich | 160 - 170                           | 18 - 25           | 2                     |
| Cakes: Madeira           | 140 - 150                           | 75 - 90           | 2                     |
| Cakes: Rich Fruit        | 140 - 150                           | 120 - 150         | 2                     |
| Cakes: Gingerbread       | 140 - 150                           | 80 - 90           | 2                     |
| Cakes: Meringues         | 90 - 100                            | 150 - 180         | 2                     |
| Cakes: Flapjack          | 160 - 170                           | 25 - 30           | 2                     |
| Casseroles: Beef / Lamb  | 160 - 170                           | 150 - 180         | 2                     |
| Casseroles: Chicken      | 160 - 180                           | 80 - 90           | 2                     |
| Convenience Foods        | Follow manufacturer's instructions. |                   | 2                     |

| <b>Food</b>                       | <b>Temperature (°C)</b>      | <b>Time (min)</b> | <b>Shelf position</b> |
|-----------------------------------|------------------------------|-------------------|-----------------------|
| Fish                              | 170 - 190                    | 20 - 30           | 2                     |
| Fish Pie (Potato Topped)          | 190 - 200                    | 20 - 30           | 2                     |
| Fruit Pies, Crumbles              | 190 - 200                    | 30 - 50           | 2                     |
| Milk Puddings                     | 150 - 170                    | 90 - 120          | 2                     |
| Pasta Lasagne etc.                | 170 - 180                    | 40 - 50           | 2                     |
| Pastry: Choux                     | 180 - 190                    | 30 - 40           | 2                     |
| Pastry: Eclairs, Profiteroles     | 180 - 190                    | 30 - 40           | 2                     |
| Pastry: Flaky / Puff Pies         | 210 - 220                    | 30 - 40           | 2                     |
| Shortcrusts: Mince Pies           | 190 - 200                    | 15 - 20           | 2                     |
| Shortcrusts: Meat Pies            | 190 - 210                    | 25 - 35           | 2                     |
| Shortcrusts: Quiche, Tarts, Flans | 180 - 200                    | 25 - 50           | 2                     |
| Scones                            | 220 - 230                    | 8 - 12            | 3                     |
| Shepard's Pie                     | 190 - 200                    | 30 - 40           | 2                     |
| Souffles                          | 170 - 180                    | 20 - 30           | 2                     |
| Vegetables: Baked Jacket Potatos  | 180 - 190                    | 60 - 90           | 2                     |
| Vegetables: Roast Potatos         | 180 - 190                    | 60 - 90           | 2                     |
| Yorkshire Pudding Large           | 220 - 210                    | 25 - 40           | 2                     |
| Yorkshire Pudding Individual      | 210 - 220                    | 15 - 25           | 2                     |
| Roasting Meat, Poultry            | Refer to the Roasting table. |                   | 2                     |

### **THERMAFLOW® BAKING - MAIN OVEN**



Shelf positions are not critical but ensure that the oven accessories are evenly spaced when more than one is used.

| <b>Food</b>          | <b>Temperature (°C)</b> | <b>Time (min)</b> | <b>Shelf position</b> |
|----------------------|-------------------------|-------------------|-----------------------|
| Biscuits             | 180 - 190               | 10 - 20           | 1 - 3                 |
| Bread                | 190 - 210               | 30 - 35           | 2                     |
| Cakes: Small & Queen | 150 - 170               | 18 - 25           | 1 - 3                 |
| Cakes: Sponges       | 160 - 170               | 20 - 25           | 3                     |
| Cakes: Madeira       | 140 - 160               | 60 - 80           | 3                     |

| Food                    | Temperature (°C)  | Time (min)                   | Shelf position |
|-------------------------|---|------------------------------|----------------|
| Cakes: Rich Fruit       | 130 - 140   | 120 - 150                    | 3              |
| Cakes: Christmas        | 130 - 140   | 180 - 270                    | 3              |
| Cakes: Apple Pie        | 160 - 170   | 50 - 60                      | 3              |
| - Shortbread            | 130 - 150   | 45 - 60                      | 1 - 3          |
| Fish                    | 160 - 180   | 30 - 40                      | 3              |
| Fruit Pies, Crumbles    | 170 - 180   | 30 - 50                      | 3              |
| Milk Puddings           | 140 - 160   | 60 - 90                      | 3              |
| Pastry: Choux           | 180 - 190   | 30 - 40                      | 3              |
| Pastry: Shortcrust      | 180 - 190   | 25 - 35                      | 3              |
| Pastry: Flaky           | 180 - 190   | 30 - 40                      | 3              |
| Pastry: Puff            | Follow manufacturer's instructions. Reduce the temperature for Fan oven by 20 °C. |                              | 3              |
| Plate Tarts             | 180 - 190   | 25 - 45                      | 3              |
| Quiches / Flans         | 170 - 180   | 25 - 45                      | 3              |
| Scones                  | 210 - 230   | 8 - 12                       | 1 - 3          |
| Roasting: Meat, Poultry | 160 - 180   | Refer to the Roasting table. | 2              |

## ROASTING

- Use heat-resistant ovenware to roast. Refer to the instructions of the ovenware manufacturer.
- You can roast large roasting joints directly in the deep pan or on the wire shelf above the deep pan.
- Put some liquid in the deep pan to prevent the meat juices or fat from burning on its surface.
- All types of meat that can be browned or have crackling can be roasted in the roasting tin without the lid.
- If necessary, turn the roast after 1/2 to 2/3 of the cooking time.
- To keep meat more succulent:
  - roast lean meat in the roasting tin with the lid or use roasting bag.
  - baste large roasts and poultry with their juices several times during roasting.

## THERMAFLOW® - MAIN OVEN

### Roasting

| Food              | Temperature (°C) | Time (min)   |
|-------------------|------------------|--|
| Beef / Beef boned | 170 - 190        | 20 - 35 minutes per 0.5 kg (1 lb) and 20 - 30 minutes over |
| Mutton / Lamb     | 170 - 190        | 20 - 35 minutes per 0.5 kg (1 lb) and 25 - 35 minutes over |

| Food              | Temperature (°C) | Time (min)   |
|-------------------|------------------|--|
| Pork / Veal / Ham | 170 - 190        | 30 - 40 minutes per 0.5 kg (1 lb) and 30 - 40 minutes over   |
| Chicken           | 180 - 200        | 20 - 25 minutes per 0.5 kg (1 lb) and 20 minutes over  |
| Turkey / Goose    | 170 - 190        | 15 - 20 minutes per 0.5 kg (1 lb) up to 3.5 kg (7 lb) then 10 minutes per 0.5 kg (1 lb) over 3.5 kg (7 lb) |
| Duck              | 180 - 200        | 25 - 35 minutes per 0.5 kg (1 lb) and 25 - 30 minutes over   |
| Pheasant          | 170 - 190        | 35 - 40 minutes per 0.5 kg (1 lb) and 35 - 40 minutes over   |
| Rabbit            | 170 - 190        | 20 minutes per 0.5 kg (1 lb) and 20 minutes over   |

### GRILLING IN GENERAL



**WARNING!** Always grill with the oven door closed.

- **Always grill with the maximum temperature setting.**
- Set the shelf into the shelf position as recommended in the grilling table.
- Always set the deep pan to collect the fat into the first shelf position.

- Grill only flat pieces of meat or fish.

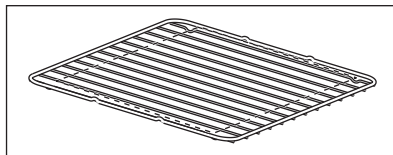

The grilling area is set in centre of the shelf.

### DUAL GRILL - TOP OVEN

| Food                           | Time (min) | Shelf position |
|--------------------------------|------------|----------------|
| Bacon Rashers                  | 5 - 6      | 3              |
| Chicken Joints                 | 20 - 40    | 2              |
| Chops - Lamb                   | 15 - 25    | 2 - 3          |
| Chops - Pork                   | 20 - 25    | 2 - 3          |
| Fish - Whole / Trout / Makarel | 10 - 12    | 2              |
| Fillets - Plaice / Cod         | 4 - 6      | 2              |
| Kebabs                         | 12 - 18    | 2 - 3          |
| Kidneys - Lamb / Pig           | 6 - 10     | 2 - 3          |
| Sausages                       | 20 - 30    | 3              |
| Steaks: Rare                   | 4 - 6      | 3              |
| Steaks: Medium                 | 6 - 8      | 3              |
| Steaks: Well Done              | 12 - 15    | 3              |

**DEFROST** 

- Remove the food packaging. Put the food on a plate.
- Do not cover it with a bowl or a plate. This can extend the defrost time.

- Use the first shelf position. The one on the bottom.

**INFORMATION FOR TEST INSTITUTES****Main oven**

| Food  | Function    | Temperature (°C) | Time (min) | Accessories | Shelf position |
|---|-------------|------------------|------------|-------------|----------------|
| Small cakes (20 small cakes per tray)                       | Thermaflow® | 150              | 20 - 30    | Tray        | 3              |
| Small cakes (20 small cakes per tray)                       | Thermaflow® | 150              | 20 - 35    | Tray        | 1 / 4          |
| Apple pie, 2 tins (ø 20 cm) on the grid, diagonally shifted | Thermaflow® | 160              | 80 - 100   | Grid        | 2              |
| Fatless sponge cake, 1 tin (ø 26 cm) on the grid            | Thermaflow® | 150              | 25 - 35    | Grid        | 2              |
| Fatless sponge cake, 1 tin (ø 26 cm) on the grid            | Thermaflow® | 150              | 30 - 40    | Grid        | 1 / 4          |
| Shortbread/Pastry strip                                     | Thermaflow® | 140              | 20 - 30    | Tray        | 3              |
| Shortbread/Pastry strip                                     | Thermaflow® | 140              | 15 - 25    | Tray        | 1 / 4          |

**Top oven**

| Food  | Function             | Temperature (°C) | Time (min) | Accessories | Shelf position |
|---|----------------------|------------------|------------|-------------|----------------|
| Small cakes (20 small cakes per tray)                       | Conventional Cooking | 150              | 20 - 30    | Tray        | 2              |
| Apple pie, 2 tins (ø 20 cm) on the grid, diagonally shifted | Conventional Cooking | 170              | 20 - 35    | Grid        | 1              |
| Fatless sponge cake, 1 tin (ø 26 cm) on the grid            | Conventional Cooking | 150              | 80 - 100   | Grid        | 2              |
| Shortbread/Pastry strip                                     | Conventional Cooking | 140              | 25 - 35    | Tray        | 2              |
| Toast   | Full Grill           | -                | 30 - 40    | Grid        | 2              |

| Food        | Function           | Temperature (°C) | Time (min) | Accessories         | Shelf position |
|-------------|--------------------|------------------|------------|---------------------|----------------|
| Beef burger | Dual Circuit Grill | -                | 20 - 30    | Grid / Roasting pan | 2              |

## OVEN - CARE AND CLEANING



**WARNING!** Refer to Safety chapters.

### NOTES ON CLEANING

- Clean the front of the appliance with a soft cloth with warm water and a cleaning agent.
- To clean metal surfaces, use a dedicated cleaning agent.
- Clean the appliance interior after each use. Fat accumulation or other food remains may result in a fire. The risk is higher for the grill pan.
- Clean stubborn dirt with a special oven cleaner.
- Clean all accessories after each use and let them dry. Use a soft cloth with warm water and a cleaning agent.
- If you have nonstick accessories, do not clean them using aggressive agents, sharp-edged objects or a dishwasher. It can cause damage to the nonstick coating.

### STAINLESS STEEL OR ALUMINIUM APPLIANCES



Clean the oven door with a damp cloth or sponge only. Dry it with a soft cloth. Do not use steel wool, acids or abrasive materials as they can damage the oven surface. Clean the oven control panel with the same precautions.

### REMOVING THE SHELF SUPPORTS

To clean the oven, remove the shelf supports.

1. Pull the front of the shelf support away from the side wall.

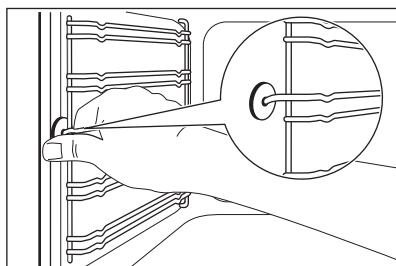

2. Pull the rear end of the shelf support away from the side wall and remove it.

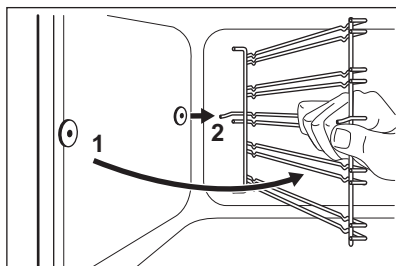

Install the shelf supports in the opposite sequence.



**CAUTION!** Make sure that the longer fixing wire is in the front. The ends of the two wires must point to the rear. Incorrect installation can cause damage to the enamel.

### REMOVING AND CLEANING THE DOOR GLASSES - TOP OVEN



The door glass in your product can be different in type and shape from the examples you see in the image. The number of glasses can also be different.

1. Open the door.

2. Hold the door trim on the top edge of the door at the two sides and push inwards to release the clip seal.

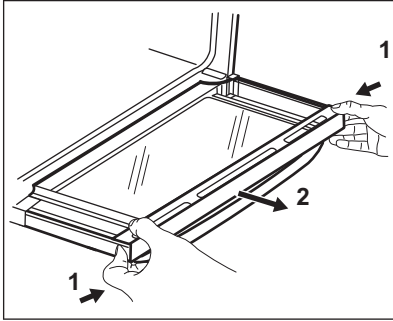

3. Pull the door trim to the front to remove it.
  4. Remove the glass panels.
- To install the panels, do the same steps in reverse.

### REMOVING AND CLEANING THE DOOR GLASSES - MAIN OVEN

**i** The door glass in your product can be different in type and shape from the example you see in the image. The number of glasses can also be different.

1. Push the door trim at one side to remove it.

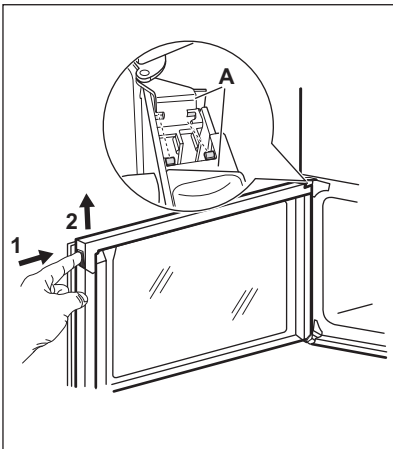

2. Pull up the trim.
3. Remove the glass panels.

**i** To replace the glass panels, do the same steps in reverse. Before you lower the trim, attach the A trim part to the door. Refer to the image.

### REPLACING THE LAMP

Put a cloth on the bottom of the interior of the appliance. It prevents damage to the lamp glass cover and the cavity.



**WARNING!** Danger of electrocution! Disconnect the fuse before you replace the lamp. The lamp and the lamp glass cover can be hot.

1. Deactivate the appliance.
2. Remove the fuses from the fuse box or deactivate the circuit breaker.

### The back lamp

**i** The lamp glass cover is at the back of the cavity.

1. Turn the lamp glass cover counterclockwise to remove it.
2. Clean the glass cover.
3. Replace the oven lamp with a suitable 300 °C heat-resistant oven lamp. Use the same oven lamp type.
4. Install the glass cover.

## TROUBLESHOOTING



**WARNING!** Refer to Safety chapters.

## WHAT TO DO IF...

| Problem  | Possible cause   | Remedy  |
|--|--|---|
| You cannot activate the appliance.   | The appliance is not connected to an electrical supply or it is connected incorrectly. | Check if the appliance is correctly connected to the electrical supply.   |
| You cannot activate the appliance.   | The fuse is blown.   | Make sure that the fuse is the cause of the malfunction. If the fuse is blown again and again, contact a qualified electrician. |
| You cannot activate or operate the hob.  | You touched 2 or more sensor fields at the same time.                                  | Touch only one sensor field.  |
| You cannot activate or operate the hob.  | There is water or fat stains on the control panel.                                     | Clean the control panel.  |
| An acoustic signal sounds and the hob deactivates.<br>An acoustic signal sounds when the hob is deactivated. | You put something on one or more sensor fields.  | Remove the object from the sensor fields.   |
| Residual heat indicator does not come on.  | The zone is not hot because it operated only for a short time.                         | If the zone operated sufficiently long to be hot, speak to an Authorised Service Centre.  |
| Automatic Heat Up function does not operate.   | The zone is hot.   | Let the zone become sufficiently cool.  |
| Automatic Heat Up function does not operate.   | The highest heat setting is set.   | The highest heat setting has the same power as the function.  |
| The sensor fields become hot.  | The cookware is too large or you put it too near to the controls.                      | Put large cookware on the rear zones if possible.   |
| There is no signal when you touch the panel sensor fields.   | The signals are deactivated.   | Activate the signals. Refer to "Hob - Daily use" chapter.   |
| [-] comes on the hob display.  | Automatic Switch Off operates.   | Deactivate the hob and activate it again.   |
| [L] comes on the hob display.  | The Child Safety Device or the Lock function operates.                                 | Refer to "Hob - Daily use" chapter.   |
| [F] comes on the hob display.  | There is no cookware on the zone.  | Put cookware on the zone.   |
| [F] comes on the hob display.  | The cookware is incorrect.   | Use the correct cookware. Refer to "Hob - Hints and tips" chapter.  |
| [F] comes on the hob display.  | The diameter of the bottom of the cookware is too small for the zone.                  | Use cookware with correct dimensions. Refer to "Hob - Hints and tips" chapter.  |



| <b>Problem</b>   | <b>Possible cause</b>                       | <b>Remedy</b>   |
|--|---|---|
| The oven does not heat up.   | The oven is deactivated.                    | Activate the oven.  |
| The oven does not heat up.   | The clock is not set.                       | Set the clock.  |
| The oven does not heat up.   | The necessary settings are not set.         | Make sure that the settings are correct.  |
| The lamp does not operate.   | The lamp is defective.                      | Replace the lamp.   |
| The display shows "12.00".   | There was a power cut.                      | Reset the clock.  |
| Steam and condensation settle on the food and in the cavity of the oven. | You left the dish in the oven for too long. | Do not leave the dishes in the oven for longer than 15 - 20 minutes after the cooking process ends. |

### SERVICE DATA

If you cannot find a solution to the problem yourself, contact your dealer or an Authorised Service Centre.

The necessary data for the service centre is on the rating plate. The rating plate is on the front frame of

the appliance cavity. Do not remove the rating plate from the appliance cavity.

**We recommend that you write the data here:**

|                      |       |
|----------------------|-------|
| Model (MOD.)         | ..... |
| Product number (PNC) | ..... |
| Serial number (S.N.) | ..... |

## INSTALLATION



**WARNING!** Refer to Safety chapters.

### TECHNICAL DATA

#### Dimensions

|        |              |
|--------|--------------|
| Height | 894 - 912 mm |
| Width  | 600 mm       |
| Depth  | 609 mm       |

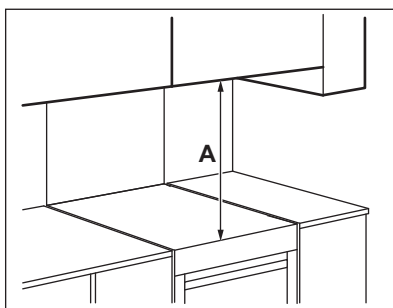

### LOCATION OF THE APPLIANCE

You can install your freestanding appliance with cabinets on one or two sides and in the corner.

## Minimum distances

| Dimension | mm  |
|-----------|-----|
| A         | 685 |

## LEVELLING OF THE APPLIANCE

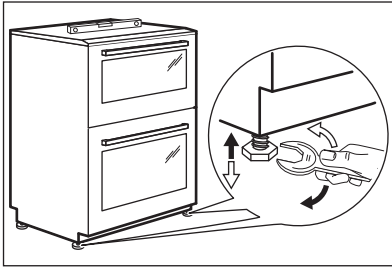

Use small feet on the bottom of appliance to set the appliance top surface level with other surfaces.

## ELECTRICAL INSTALLATION



**WARNING!** The manufacturer is not responsible if you do not follow the safety precautions from Safety chapters.

This appliance is supplied without a main plug or a main cable.

### Applicable types of cables for different phases:

| Phase          | Min. size cable       |
|----------------|-----------------------|
| 1              | 3x6.0 mm <sup>2</sup> |
| 3 with neutral | 5x1.5 mm <sup>2</sup> |



**WARNING!** The power cable must not touch the part of the appliance shaded in the illustration.

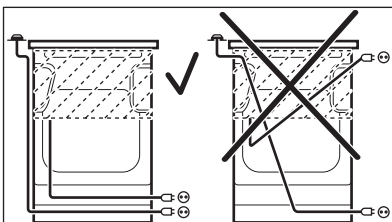

## COVERING TERMINAL BOARD

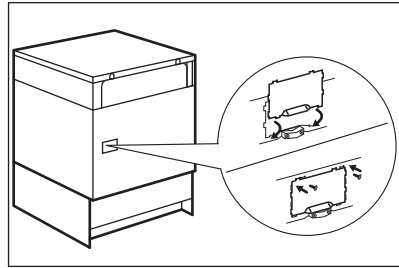

- The recommended cross-section area is six square millimetres (6 mm<sup>2</sup>).
- When you refit the mains terminal cover, make sure that the lower tabs are located inside the bottom edge of the aperture, before you fix the two screws into the top edge of the mains terminal cover.
- Make sure that the cover is securely fastened.



To open the cover of terminal board obey the procedure in opposite sequence.

## TERMINAL BOARD



Do not remove blanking plates.

Make sure that the links are fitted as shown.

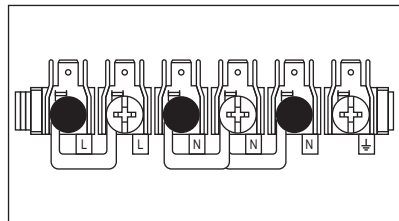

# ENERGY EFFICIENCY

## PRODUCT INFORMATION FOR HOB ACCORDING TO EU 66/2014

|   |  |  |
|---|--|--|
| Model identification                                      | ZCI66278XA   |  |
| Type of hob   | Hob inside Freestanding Cooker                       |  |
| Number of cooking zones                                   | 4  |  |
| Heating technology  | Induction  |  |
| Diameter of circular cooking zones (Ø)                    | Left front<br>Left rear<br>Right front<br>Right rear | 21.0 cm<br>14.0 cm<br>18.0 cm<br>18.0 cm                 |
| Energy consumption per cooking zone (EC electric cooking) | Left front<br>Left rear<br>Right front<br>Right rear | 171.4 Wh/kg<br>176.4 Wh/kg<br>171.2 Wh/kg<br>166.2 Wh/kg |
| Energy consumption of the hob (EC electric hob)           | 171.3 Wh/kg  |  |

EN 60350-2 - Household electric cooking appliances - Part 2: Hobs - Methods for measuring performance.

### HOB - ENERGY SAVING

You can save energy during everyday cooking if you follow below hints.

- When you heat up water, use only the amount you need.
- If it is possible, always put the lids on the cookware.

- Before you activate the cooking zone put the cookware on it.
- Put the smaller cookware on the smaller cooking zones.
- Put the cookware directly in the centre of the cooking zone.
- Use the residual heat to keep the food warm or to melt it.

## PRODUCT FICHE AND INFORMATION FOR OVENS ACCORDING TO EU 65-66/2014

|  |   |
|--|---|
| Supplier's name  | Zanussi   |
| Model identification                                       | ZCI66278XA  |
| Energy Efficiency Index                                    | Top oven: 105.6<br>Main oven: 95.4                    |
| Energy efficiency class                                    | Top oven: A<br>Main oven: A                           |
| Energy consumption with a standard load, conventional mode | Top oven: 0.75 kWh/cycle<br>Main oven: not applicable |
| Energy consumption with a standard load, fan-forced mode   | Top oven: not applicable<br>Main oven: 0.83 kWh/cycle |
| Number of cavities   | 2   |
| Heat source  | Electricity   |
| Volume   | Top oven: 39 l<br>Main oven: 77 l                     |

|              |                                 |
|--------------|---------------------------------|
| Type of oven | Oven inside Freestanding Cooker |
| Mass         | 61.0 kg                         |

EN 60350-1 - Household electric cooking appliances - Part 1: Ranges, ovens, steam ovens and grills - Methods for measuring performance.

### OVEN - ENERGY SAVING



The oven contains features which help you save energy during everyday cooking.

### General hints

Make sure that the oven door is closed properly when the appliance operates. Do not open the door too often during cooking. Keep the door gasket clean and make sure it is well fixed in its position.

Use metal dishes to improve energy saving.

When possible, do not preheat the oven before you put the food inside.

## ENVIRONMENTAL CONCERNS

Recycle materials with the symbol . Put the packaging in relevant containers to recycle it. Help protect the environment and human health by recycling waste of electrical and electronic appliances. Do not dispose of appliances marked

When the cooking duration is longer than 30 minutes, reduce the oven temperature to minimum 3 - 10 minutes before the end of the cooking time, depending on the duration of the cooking. The residual heat inside the oven will continue to cook.

Use the residual heat to warm up other dishes.

Keep breaks between baking as short as possible when you prepare few dishes at one time.

### Cooking with fan

When possible, use the cooking functions with fan to save energy.

### Keep food warm

Choose the lowest possible temperature setting to use residual heat and keep a meal warm.

with the symbol  with the household waste. Return the product to your local recycling facility or contact your municipal office.







[WWW.ZANUSSI.COM/SHOP](http://WWW.ZANUSSI.COM/SHOP)



CE

867337961-B-192018