

Thank you for your trust and for buying this appliance. We hope it will successfully serve the purpose for many years.

The appliance is intended solely for household use.

The upper part of the appliance is refrigerator and is used for storing fresh foods at the temperature of 0°C and higher.

The lower part is freezer and is used for freezing fresh foods and storing frozen foods for longer periods of time (up to one year, depending on the kind of foods you store). The compartment is marked with four stars.

Before Putting Into Use	2	Operation Control	6
Instructions for Use		Temperature Selection	
Mounting Instructions		Use.....	7
We Care for the Environment		Storing Fresh Foods	
Tips for Energy Savings		Freezing Fresh Foods	
Important	3	Storing Frozen Foods	
Storing Time During Power Supply Interruption		Maintenance and Cleaning.....	9
Disposing of the Worn Out Appliance		Automatic Defrosting of the Refrigerator	
Placing and Installation	4	Manual Defrosting of the Freezer	
Choosing the Right Place		Cleaning the Appliance	
Connection to Power Supply		Switch Off the Appliance When Not In Use	
Description of the Appliance.....	5	Trouble-Shooting Guide	10
Refrigerator (A)			
Freezer (B)			

Before Putting Into Use

- Before connecting the appliance to the mains supply, leave it stand for about 2 hours, which will reduce a possibility of malfunctions in the cooling system due to transport handling.
- Clean the appliance, and be thorough, especially in the interior (See Cleaning and Maintenance).
- In case the interior accessories are not correctly placed, rearrange them as described in chapter "Description of the Appliance".

Instructions for Use

These instructions for use are intended for the user. They describe the appliance and its correct and safe use. They were prepared for various types/models of appliances therefore you may find in it description of some functions and accessories that your appliance does not have.

Mounting Instructions

Integrated appliances are equipped with instructions for mounting the appliance into the kitchen unit.
The appliance should be professionally mounted by qualified technician and instructions are for his use only.

We Care for the Environment

- Our products use environmentally friendly packaging, which can be either recycled or disposed of in an environmentally friendly manner. To this end, individual packaging materials are clearly marked.
- These instructions are printed either on recycled paper or chlorine free bleached paper.
- When your appliance finally wears out, please try not to burden the environment with it; call your nearest authorised service agent. (See Disposing of the Worn Out Appliance)

Tips for Energy Savings

- Try not to open the door too often, especially when the weather is wet and hot. Once you open the door, mind to close it as soon as possible. This is especially important if you have an upright model.
- Every now and then check if the appliance is sufficiently ventilated (adequate air circulation behind the appliance).

- Set thermostat to lower settings as soon as possible (depends on the amount of food loaded, ambient temperature etc).
- Never use continuous operation unless unnecessarily required; switch the operation mode selection switch to the setting for automatic operation as soon as possible.
- Before loading the appliance with packages of fresh foods, make sure they are cooled to ambient temperature.
- Ice and frost layer increase energy consumption, so do clean the appliance as soon as the layer is 3-5 mm thick.
- If the gasket is damaged or if it turns out that the sealing is poor, the energy consumption is substantially higher. To restore efficiency, replace the gasket.
- The condenser on the rear wall should be always clean, free of dust or any impurities.
- Always consider instructions stated in sections Positioning and Energy Saving Tips, otherwise the energy consumption is substantially higher.

Important

- This appliance can be used by children aged from 8 years and above and persons with reduced physical, sensory or mental capabilities or lack of experience and knowledge if they have been given supervision or instruction concerning use of the appliance in a safe way and understand the hazards involved. Children shall not play with the appliance. Cleaning and user maintenance shall not be made by children without supervision.
 - If you have bought this appliance to replace an old one equipped with a lock that cannot be opened from inside (lock, bolt), make sure that the lock is broken. This will make it impossible for children to lock themselves inside the appliance and suffocate.
 - The appliance must be correctly connected to the mains supply. (see: Connecting to the Mains Supply).
 - If the food has strange smell or color, throw it away, because it is very likely that it is spoiled and therefore dangerous to eat.
 - Disconnect the appliance from the power supply before repairing it (only a qualified technician should repair it), before cleaning and before replacing the light bulb.
 - Do not defrost the appliance with other electric appliances (as for example with hair dryer) and never scrape the frost layer with sharp objects. Use only enclosed tools or tools recommended by the manufacturer.
 - For the sake of environment protection - be careful not to damage the rear wall of the appliance (the condenser unit or the tubes - for example when moving the appliance) or any part of the refrigerating system inside the appliance.
 - The refrigerating system of the appliance is filled with refrigerant and oil, so when the appliance is damaged, handle it with care and dispose it of in compliance with environmental protecting precautions. (See We Care for the Environment).
 - Heating element incorporated in the appliance, all around the rim, is controlled by the operation of the compressor and it prevents the door gasket to freeze on to the freezer housing.
 - If the supply cord is damaged, it must be replaced by the manufacturer or his service agent or a qualified person in order to avoid hazard.
 - The rating plate is inside the appliance or outside on the rear wall.
- **WARNING!** Ventilation openings on the appliance or built-in cupboard must be kept clean and unobstructed at all times.
 - **WARNING!** Do not use any mechanical accessories or other methods to defrost the appliance, except for those expressly recommended by the manufacturer.
 - **WARNING!** During installation, cleaning, and removal of appliance, be careful not to damage the insulation of the parts of the cooling system.

This will also prevent pollution.

- **WARNING!** Do not use any electric devices inside the appliance, except for those allowed by the manufacturer of this refrigeration appliance.



The symbol on the product or on its packaging indicates that this product may not be treated as household waste.

Instead it shall be handed over to the applicable collection point for the recycling of electrical and electronic equipment. By ensuring this product is disposed of correctly, you will help prevent potential negative consequences for the environment and human health, which could otherwise be caused by inappropriate waste handling of this product.

For more detailed information about recycling of this product, please contact your local city office, your household waste disposal service or the shop where you purchased the product.

Storing Time During Power Supply Interruption

Do not open the freezer in case of failure or power supply interruption! In case the interruption is extended over longer period of time (13 hours for HZDI 2121/6, 14 hours for HZDI 2621/6 and 15 hours for HZDI 2521/6), take food out of the freezer and use it, or make sure that is sufficiently cooled (perhaps you have an extra appliance).

Disposing of the Worn Out Appliance

- When your appliance finally wears out, dispose it of. If the appliance has a lock, break it, in order to prevent eventual accidents (danger of children get locked inside the appliance).
- The refrigerating system of the appliance is filled with refrigerant and insulating substances which should be separately treated and processed. Call your nearest authorised service agent or specialised servicing centre. If you don't find one, contact your local authorities or your distributor. Be careful not to damage the tubes on the rear wall of the appliance (danger of pollution).

Placing and Installation

Choosing the Right Place

Place the appliance in a dry and regularly ventilated room. Allowed ambient temperature depends on the model (class) of the appliance and is stated on the rating plate of the appliance. Never place the appliance near heat emitting devices (e.g. cooker, radiator, water heater or similar devices) and do not expose it to direct sunlight.

The appliance should be positioned at least 3 cm away from the electric or gas cooker and at least 30 cm away from the oil or coal stove. If this is not possible, use an appropriate insulation. Behind the appliance there should be free space at least 200 cm² wide and above the appliance the high kitchen units should be at least 5 cm away from the appliance in order to assure adequate ventilation of the condenser unit.

Class	Ambient temperature
SN (sub-normal)	from + 10°C to + 32°C
N (normal)	from + 16°C to + 32°C
ST (sub-tropical)	from + 16°C to + 38°C
T (tropical)	from + 16°C to + 43°C

Connection to Power Supply

Connect the appliance with the cable and plug to the power supply socket outlet with a ground terminal (safety socket).

Required nominal voltage and frequency are indicated on the rating plate.

The connection to the mains supply and earthing have to be made according to current standards and regulations. The appliance resists temporary voltage tolerance up to -6 to +6 %.

Warning: when installing built-in appliances into a cupboard or cabinet in a side-by-side layout, the dew prevention installation kit should also be purchased and installed. **For safety reasons, dew prevention kit may only be installed by an authorized service technician!**

Order code: 376078 (appliances higher than 1,700 mm)

Description of the Appliance

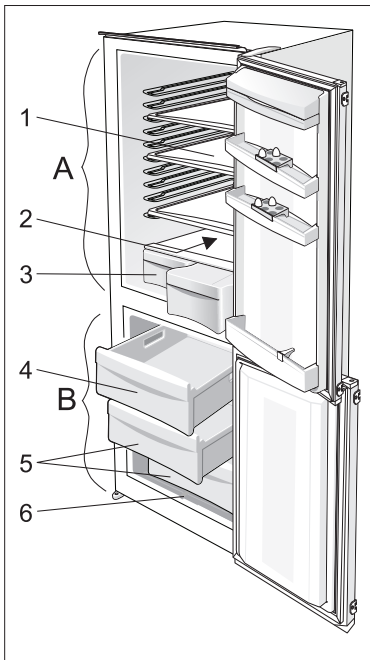
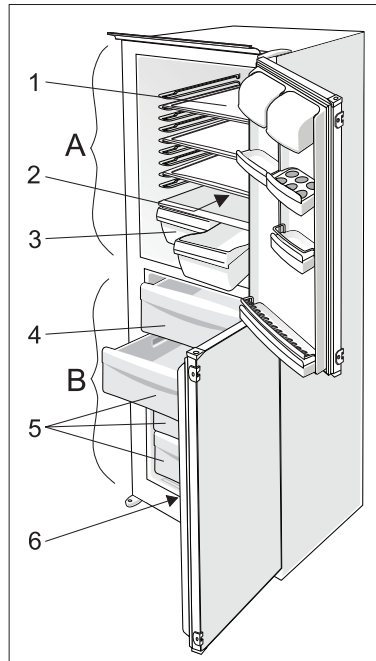
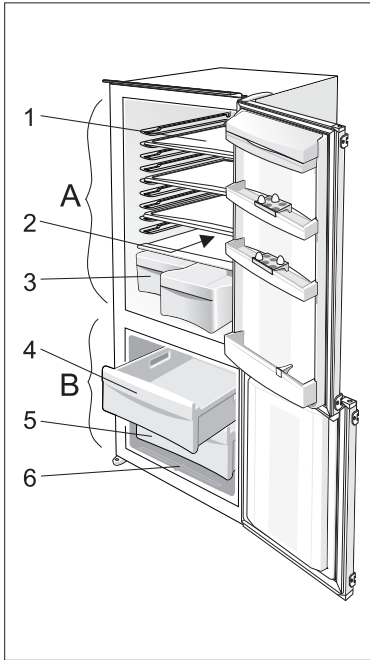

Refrigerator (A)

Refrigerator is used for storing fresh foods for few days.

Shelf (1)
(number depends on the model)

Shelf can be optionally placed on the guides inside the appliance. It is protected against pulling out. If you want to remove it, slightly lift up the back part and pull it out.

Glass shelves (some models only have them) are protected with plastic spacers. Before pulling the shelf out, spacers must be moved towards you. Spacers can be also removed, however, it is better to keep them for any later transport.

Quickly perishable food should be stored on the back i.e. the coldest part of the shelves.

Bottle rack
(in some models only)

Bottle rack (number depends on model) is intended for storing the bottles. There are two installation positions available (horizontal or lifted in the front) thus enabling the positioning of bottles on the stopper as well.

It is protected against pulling out. If you want to pull it out, simply lift its rear part and pull it towards you.

Warning!

If the door contains storing shelves, install the rack in such position that the length of the bottles will not hinder the closing of the door.

The rack may carry 9 bottles of 0,75 l or more at the maximum (total weight max. 13 kg) – note the label underneath the thermostat box inside the appliance.

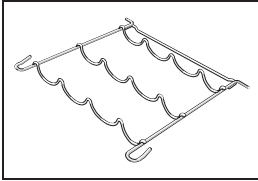

Defrost Water Outlet (2)

The interior of the refrigerator is cooled with cooling plate incorporated in the rear wall. Under the plate there is a channel and an outlet for defrost water.

Regularly check the defrost water outlet and the channel, because they should never be clogged (as for example with food rests). If clogged, use a plastic straw and clean it.

Fruit and Vegetable Container (3)

The container is on the bottom under the glass shelf and is used mainly for storing fruits and vegetables. It provides adequate humidity which has favourable effect on food stored (less dehydration).

The fan

(certain models only)

- The fan distributes evenly the inside temperature and reduces dew on storage shelf surfaces.
- When the refrigerator door is opened, the fan stops operating.
- It is recommended to switch the fan on:
 - when the ambient temperature in the room is increased (above 30°C),
 - in case of increased humidity (during summer season).

• Switching the fan on/off

ON =  OFF = 0

Note: Energy consumption is increased during fan operation.

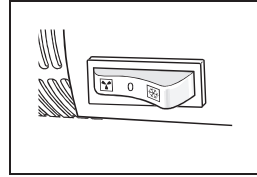

Door Liner

The door liner consists of various shelves or holders used for storing eggs, cheese, butter and yogurt as well as other smaller packages, tubes, cans etc.

The lower shelf is used for storing bottles.

Illumination in the Interior of the Refrigerator

The light for illuminating the interior of the appliance is on, when the door is opened. The operation of the light does not depend on the position of the thermostat knob.

Freezer (B)

Freezer is used for freezing fresh foods and for storing already frozen foods.

Freezing Compartment (4)

is used for freezing fresh foods.

Storing Compartment (5)

is used for storing packages of frozen foods.

Defrost Water Outlet (6)

(See Cleaning and Maintenance).

NOTE:

- The appliance can be equipped with various accessories, depending on the model of the appliance.
- Various accessories (spice container, tube holder or additional shelves) can be bought in authorized centres.

Operation Control

The appliance is controlled with thermostat knob, situated in the right upper part inside the refrigerator. Turn the knob clockwise from **STOP (0)** position towards **7** and backwards.

Temperature Selection

- Higher settings on the knob (towards **7**) mean lower temperatures (colder) in all compartments of the appliance. At higher settings temperature in the interior of the appliance may even drop below 0°C.

When the ambient temperature is normal, we recommend medium setting.

- Changes of the ambient temperature affect temperature in the interior of the appliance (choose correct setting of the thermostat knob)

- In **STOP (0)** position the appliance does not operate (the cooling system is switched off), yet power supply is not interrupted (the light is on, when you open the refrigerator door).
- When the fan is on (only for models with built-in fan), we recommend new setting of temperature in the appliance.

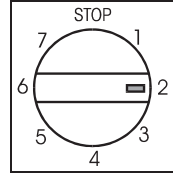
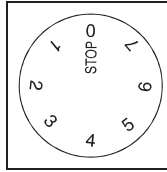

Use

Storing Fresh Foods

Proper use of the appliance, adequately packed food, correct temperature and taking into account hygienic precautions will substantially influence the quality of the food stored.

- Foods to be stored in the refrigerator should be properly packed as to prevent mixing various moisture degrees and odors (in polyethylene bags or sheet, aluminium foil, wax paper), or stored in covered containers or bottles.
- Before storing food in the refrigerator, remove the excessive packaging (like yoghurt in multi-package).
- Pack systematically and make sure that foodstuffs do not touch each other (various odours may mix). Assure adequate air circulation around packages.
- Never store inflammable, volatile or explosive substances.
- Beverages with high alcohol percentage shall be stored in tightly sealed bottles in vertical position.
- Food should not touch the rear wall of the refrigerator!
- Foods should be cooled down before storing.
- Crispy and delicate foods should be stored in the coldest parts of the refrigerator.
- Try not to open the door too often.

- Set the thermostat to the setting where lower temperatures are reached. Set the thermostat gradually as to avoid freezing of the foods. Use a thermometer and measure the temperature in the individual compartments. Place the thermostat in a glass vessel filled with water. Temperature readings are most reliable few hour after steady state is reached.
- Some organic solutions like volatile oils in lemon or orange peel, acid in butter etc. can cause damage and when in contact with plastic surfaces or gaskets for longer period of time they can cause accelerated ageing of the plastic material.
- Unpleasant odor inside the refrigerator is a sign that something is wrong with foods or that your refrigerator needs cleaning. Unpleasant odor can be eliminated or reduced by washing the interior of the refrigerator with a mild solution of water and vinegar. We also recommend using activated carbon filters to clean the air or to neutralize odors.
- If you plan a longer journey, make sure to remove quickly perishable articles of food out of the appliance before you leave.

Fresh Food Storage Time in the Refrigerator

Fresh Food Storage	Storage time (days)													
	1	2	3	4	5	6	7	8	9	10	11	12	13	14
Butter	+	+	+	+	+	+	+	=	=	=	=	=	=	=
Eggs	+	+	+	+	+	+	+	+	+	+	=	=	=	=
Meat: fresh uncut	+	+	=											
	+	=												
	+	+	+	+	+	+	+	+	+	+	=	=	=	=
Fish	+	=												
Marinade	+	+	+	+	+	+	+	+	+	+	=	=	=	=
Root	+	+	+	+	+	+	+	+	=	=	=	=	=	=
Cheese	+	+	+	+	=	=	=	=	=	=	=	=	=	=
Sweets	+	+	=	=	=	=	=	=	=	=	=	=	=	=
Fruit	+	+	=	=	=	=	=	=	=	=	=	=	=	=
Prepared dishes	+	+	=	=	=	=	=	=	=	=	=	=	=	=

Legend: + recommended storage time = possible storage time

Freezing Fresh Foods

- Carefully select food you intend to freeze; it should be of adequate quality and suitable for freezing.
- Use correct packaging and wrap it right.
 - The packaging should be air tight and shouldn't leak since this could cause substantial vitamin loss and dehydration of foods.

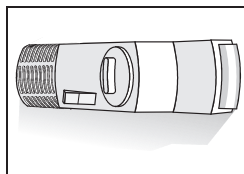
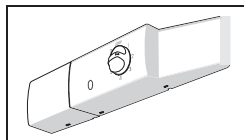

- Foils and bags should be soft enough to tightly wrap around the foods.
- Mark packages with following data: kind and amount of foods and the date of loading.
- It is most important that the food is frozen as quickly as possible. Therefore we recommend the size of the package not to be too large and to be cooled before loading into the freezer.
- The amount of fresh foods that can be loaded in the freezer within 24 hours is indicated on the rating plate (freezing capacity). If the loaded amount is too large, the quality of freezing is reduced which affects the quality of frozen foods.



Freezing Procedure

• **If you have a model without the integrated switch for intensive cooling**, turn the thermostat knob to position **4-6** some 24 hours before loading. After 24 hours load the freezer shelf with fresh food packages. Some 24 hours after loading, turn the thermostat knob to operating position if necessary (see "Temperature selection"), and then reload the frozen packages into the storage baskets (storing compartment).

- The next time you want to freeze fresh foods, repeat the freezing procedure and be careful that packages with fresh foods do not touch frozen packages.
- For freezing smaller amount of foods (up to 1 kg) there is no need to change the thermostat setting (see Temperature Selection).

If you have a model with integrated switch for intensive cooling, switch it on some 24 hours before loading the appliance with larger amounts of fresh foods and turn the thermostat knob to position **4-6**. After 24 hours load the appliance with fresh food packages. After loading, wait for another 24 hours and **switch off the switch** and turn the thermostat knob to required position (see "Temperature selection"). The switch is ON when the marking  (I) or colour marking is visible, and OFF when the marking  (0) is visible or colour marking is not visible (depending on model).

Storing Frozen Foods

Packages of frozen foods are stored in the basket. If you remove the baskets, you can store frozen packages directly on the cooling shelves.

Commercially Frozen Foods

The storage time and the recommended temperature for storing commercially frozen foods are indicated on the packaging. For storing and using consider the manufacturer's instruction. When shopping, be careful and choose only adequately packed foods provided with complete data and stored in freezers where the temperature is not higher than -18°C. Do not buy packages of food covered with frost layer. This indicates that the package was thawed before at least once. Be careful that packages don't start to thaw, as the temperature raise reduces the quality of foods.

Approximate Storage Time for Frozen Foods

Food	Storage time (in months)											
	1	2	3	4	5	6	7	8	9	10	11	12
Vegetable								+	+	+		
Fruit										+	+	+
Bread, pastries			+									
Milk			+									
Ready-made meals			+									
Meat: Beef										+	+	+
Veal								+	+	+		
Pork				+	+	+						
Poultry							+	+	+			
Game						+	+	+				
Minced meat				+								
Smoked sausages	+											
Fish: lean			+									
fat	+											
Offal		+										

Defrosting Frozen Food

Partially thawed or defrosted foods should be used as soon as possible. Cold air preserves the food but it does not destroy microorganisms which

rapidly activate after defrosting and make foods perishable.

Partial defrosting reduces the nutritional value of foods, especially of fruits, vegetables and ready-made meals.

Maintenance and Cleaning

Automatic Defrosting of the Refrigerator

There is no need to defrost the refrigerator, because ice depositing on the inner back wall is defrosted automatically.

Ice is depositing on the inner back wall during the compressor operation; later on, when the compressor is not operating ice is defrosting and water drops collect and drain through the outlet in the inner back wall into the drain pan situated above the compressor, from where it evaporates.

Manual Defrosting of the Freezer

When the frost and ice layer in the freezer is 3-5 mm thick, you should clean the freezer.

- Few hours before defrosting set the thermostat to position **7**, so that packages are well frozen. Reset the thermostat to **STOP (0)** position and disconnect the power supply. Empty the freezer and take care that the packages remain frozen.
- Insert the enclosed pipe into the groove in the bottom of the appliance and place a vessel underneath to collect the defrost water. Defrosting is accelerated if the door is left open.

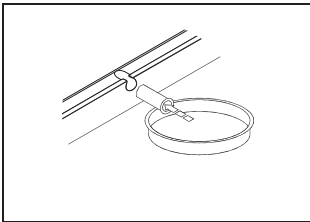

- Avoid using defrosting sprays, as they may cause damage to the plastic parts and may be hazardous to health.

Cleaning the Appliance

Disconnect the power supply before cleaning the appliance.

Do not use coarse or aggressive cleaning agents as you can damage the surface. Be careful to remove any cleanser agent remaining after cleaning.

- Clean the **exterior** with water and detergent. Varnished surfaces are cleaned with soft cloth and an alcohol based cleaning agent (for example glass cleaners). You may also use alcohol (ethanol or isopropyl alcohol).

The application of abrasive and specially aggressive cleaners, such as the stainless steel cleaners, is not appropriate for the cleaning of plastic and coated parts.

- Remove the **detachable accessories** in the interior of the appliance and clean it with water and liquid detergent. Plastic parts cannot be washed in washing machine.
- Wash the **interior** of the appliance with lukewarm water, in which you added one or two spoonfuls of vinegar.
- Every now and then wipe the **condenser** on the rear wall. Use soft non-metal brush or vacuum cleaner.

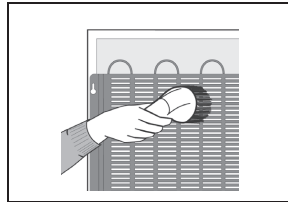

- Do not forget to clean also the defrost water **receptacle** above the refrigerator compressor (do not remove the receptacle).

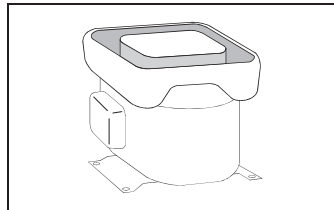

After cleaning, connect the appliance to power supply and reload the packages.

Switch Off the Appliance When Not In Use

If you do not intend to use the appliance for a longer period, set the thermostat knob to the **STOP (0)** position, disconnect the power supply, take out the foods and defrost and clean the appliance. Leave the door slightly open.

? Trouble-Shooting Guide

During the service, you can come across some troubles that in most cases result from improper handling of the appliance and can easily be eliminated.

The Appliance Fails to Operate After connecting to the Mains Supply

- Check the supply in the outlet socket and make sure the appliance is switched on (thermostat in operating position).

Continuous Operation of the Refrigerating System

- The door was frequently opened or it was left opened for too long.
- The door is not properly closed (the door may sag, the gasket may be polluted or damaged).
- Perhaps you have overloaded the appliance with fresh foods.
- The reason may be inadequate ventilation of the compressor and condenser (assure adequate air circulation and wipe off the condenser).
- Continuous operation button activated (see section Freezing of Food).

Ice Formation on the Inner Rear Wall

As long as the defrost water runs to the channel and through the opening to the drain pan on the compressor, automatic defrosting of the appliance is assured.

In case the ice formation on the inner back wall is increased (3-5 mm), ice should be manually defrosted.

Set the thermostat knob to **STOP (0)** position and leave the door open. Never use electric devices for defrosting and do not scrape the ice or frost layer with sharp objects.

After completed defrosting, turn the knob to desired position and close the refrigerator door.

The cause of increased ice formation may be one of the following:

- the door does not seal well (clean the gasket if it is contaminated, or replace it if it is damaged);
- the door was frequently opened or it was left opened for too long;
- the food stored in the refrigerator was warm;
- the food or dish is touching the inner back wall.

Water is Leaking From the Refrigerator

In case the discharge water outlet is clogged, or the defrost water drips over the channel, water leaks from the refrigerator.

- Clean the clogged opening, for example with a plastic straw.
- Manually defrost the increased ice layer. See "Ice Formation on the Inner Back Wall".

The Freezer Door is Hard to Open

If you want to open the door that has just or recently been closed, you may find it hard to open. The reason why this happens is, that when you open the door, warm air gets into the appliance and when it is getting cool, the underpressure seals the door. After few minutes (5-10), the door can easily be opened.

Noise

Cooling in refrigerating-freezing appliances is enabled by the refrigerating system with compressor, which produces noise. How noisy the appliance is depends on where it is placed, how it is used and how old the appliance is.

- **During the operation** of the compressor the noise of liquid is heard and when the compressor is not operating, the refrigerant flow is heard. This is a normal condition and it has no influence whatsoever on the lifetime of the appliance.
- **After starting the appliance**, the operation of the compressor and the refrigerant flow may be louder, which does not mean that something is wrong with the appliance and it has no influence on the lifetime of the appliance. Gradually the noise is reduced.
- Sometimes **unusual and stronger noise** is heard, which is rather unusual for the appliance. This noise is often a consequence of inadequate placing.
 - The appliance shall be placed and levelled firmly on solid base.
 - It should not touch the wall or kitchen units standing next to it.
 - Check the accessories in the interior of the appliance, they should be placed correctly in their positions; also check the bottles, tins and other vessels that might touch each other and rattle.

Bulb Replacement

Before replacing the light bulb, disconnect the appliance from the power supply.

Press the cover at the rear side (in the arrow 1 direction) and remove the plastic cover (in the arrow 2 direction). Replace the bulb with a new one (E14, max. 15 W).

Don't forget: the old bulb does not belong to organic waste.

Light bulb is consuming good therefore our in-guarantee service does not relate to it.

Bulb lamps used in this appliance are special purpose lamps selected for household appliances use only. They are not suitable for household room illumination.

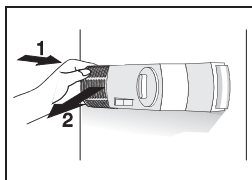
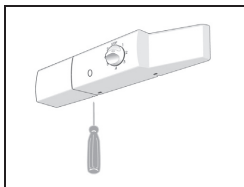

WE RESERVE THE RIGHT TO ALTER THE SPECIFICATIONS WITH NO INFLUENCE ON THE OPERATION OF THE APPLIANCE.

Instructions for use of the appliance can also be found on our website at www.gorenje.com / <
<http://www.gorenje.com> />