

Installers &
User guide
Keybox 3.

Welcome!

This guide will get you up and running with your igloohome Keybox 3. In the meantime, you should follow igloohome on Facebook and Youtube!



Like us on Facebook



Visit our Youtube



As our igloohome app is frequently updated, there may be changes to this manual. Please refer to our website igloohome.co/support for the latest version of the manual.

Table of Contents

What's Included	4
Specifications	5
Features	6
Quick Start Guide	8
App Onboarding	9
Managing Access in App	10
Unlocking	11
Locking	12
Lock Installation	13
Lock Behaviour	15
USB-C Jumpstart	16
Audio and LED Indications	17
Troubleshoot	18

What's Included

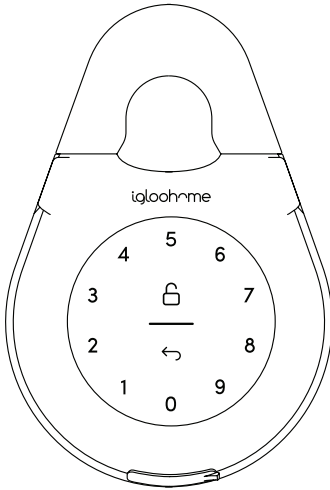

Keybox 3

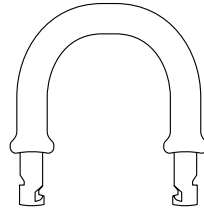

Slim Shackle



Mounting Seal Rings x2

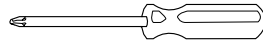

Screwdriver



Mounting Screws x2



Screws Anchors x2

Specifications

Model	igloohome Smart Keybox 3
Battery Type	4 x AAA Alkaline Batteries
Battery Life	Up to 12 months
Emergency Power	USB-C Jumpstart
Operation Temp	-20°C to 50°C
IP Rating	IP66
Body Material	Zinc Alloy, Aluminium Alloy, Acrylic
Shackle Material	Hardened Steel, Rubber
Weight	Net: 1kg, Gross: 1.3kg
Unlock Mechanism	Bluetooth, PIN code

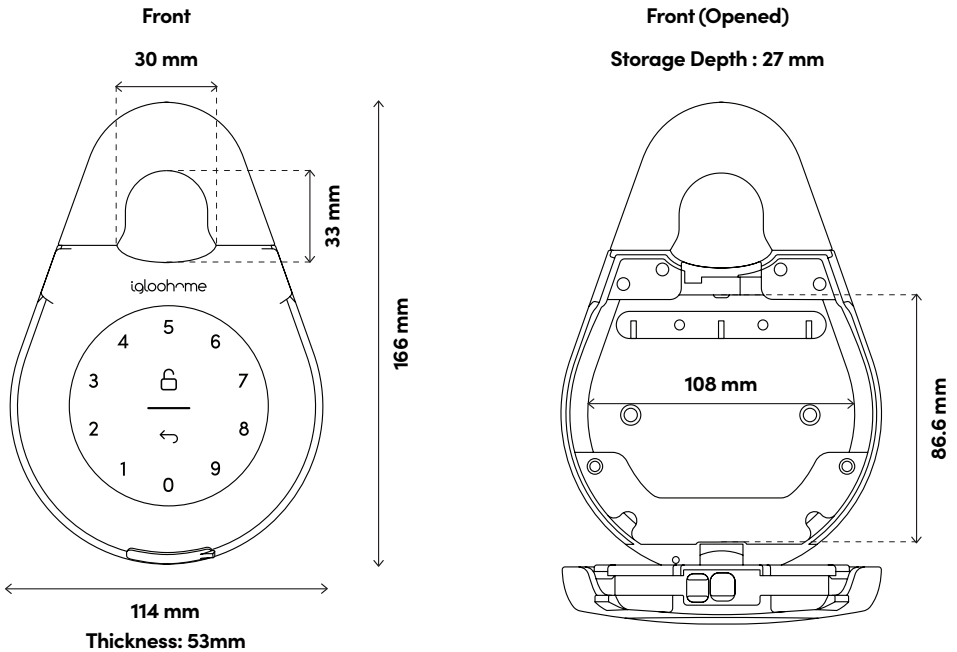

* **DO NOT USE:** Heavy Duty, Eveready, GP, or rechargeable batteries. Duracell & Energizer alkaline batteries recommended. Please note that using better batteries will improve the performance and lifespan of the lock.

Features

PIN / Bluetooth Unlock



Master PIN Code

The igloohome Keybox 3 unlocks with a permanent Master PIN Code.



Bluetooth Master Key

The igloohome Keybox 3 unlocks with Bluetooth via the app.



User PIN Code

The igloohome mobile app can generate multiple types of User Pin codes, e.g. One-Time, Permanent & Duration.



Bluetooth Guest Key

The igloohome mobile app can generate and share Bluetooth keys based on duration with guests to unlock the Keybox 3.

Battery



Battery Life

The Keybox 3 can last up to 12 months with 4 AAA Alkaline battery.



Emergency Jump Start

If battery power is drained, connect a USB-A to USB-C cable to a power bank then plug it onto the USB-C jumpstart port on the keybox to provide emergency power.



Low Battery Indicator

The Status Indicator shows red light when battery level is 20% and below, followed by a sound alert when the keypad is woken up. The battery level can also be monitored on the app and is updated during Bluetooth Unlock.

Features

Security



Keypad Security Lockout

Lock will disallow any PIN entries and sound an alarm when there is a number of incorrect PIN attempt. User can configure number of incorrect attempts to trigger timeout.



Masking Security Code

A total of 16 digits including the masking digits can be entered to prevent the PIN code from being exposed.



Auto Relock

The Keybox 3 relocks automatically when product is closed. User can deactivate auto-relock function if they prefer manual relock.



Weather Resistant

The Keybox 3 is able to withstand weather conditions with protection against dust and water (IP66).

Quick Start Guide

- 1** Loosen the 4 screws and remove battery cover

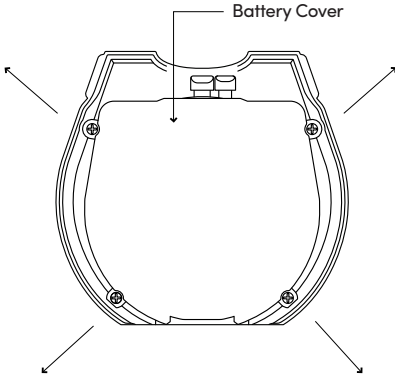

- 2** Insert AAA Batteries

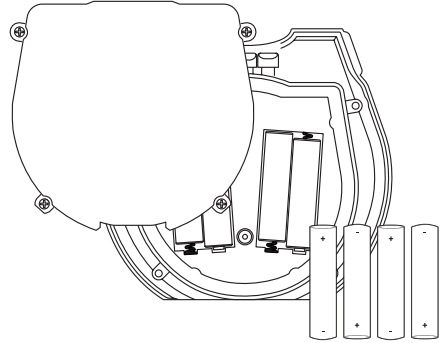

- 3** Secure battery cover tightly with 4 screws

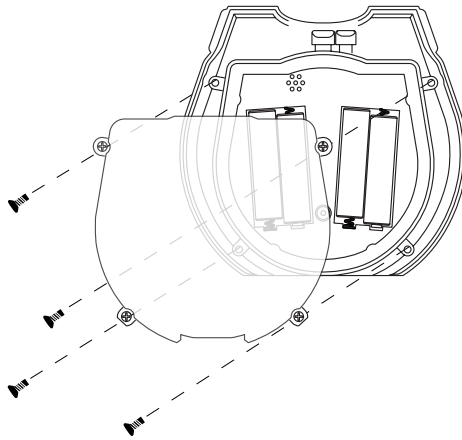

 Please screw the battery cover tightly after inserting batteries to ensure optimal water resistance.

App Onboarding

1 Test Factory PIN Unlock

In the factory mode (before pairing), the PIN to unlock the lock is **1 2 3 4 5 6 7 8 9 0** 

2 Register as a Lock User

- Download igloohome from the App Store / Play Store
 - Create an account and login
-

3 Pairing

- Select **[Add new igloohome lock]**

Note: For existing users with other paired locks, go to **[Configuration]**, select **[Add Locks]** and follow the instructions.

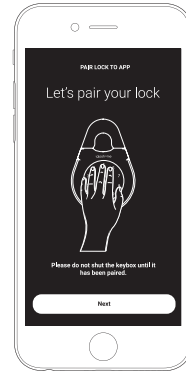

4 Setting Master PIN Code

Before proceeding, turn on your Bluetooth and ensure that you are within Bluetooth range of the lock.

Go to **[Access]** and customize your **[Master PIN]** by editing it.

Managing Access in App

1 Creating PIN codes

PIN codes can be generated on the app under **[Access]**, press **[+Access]** and choose either One-Time, Permanent or Duration PIN.

Pin codes will expire if its not use within its activation period. Refer to the table below.

PIN Type	Use PIN within*
Permanent PIN	24 hrs of generation
One-Time PIN	24hrs of generation
Duration PIN	24hrs from the start time

Note: Duration PIN code end times can be customised within a 28-day timeframe. Past this timeframe, the end time will automatically be configured to the start time.

2 Bluetooth Guest Key

Bluetooth Guest Key can be shared with other users for mobile access. It allows your guests to unlock the igloohome smart lock via Bluetooth.

There are 3 steps to using a Shared Bluetooth Key

1. Under **[Access]**, press **[+Access]** and choose **[Bluetooth Key]** under **[Access Type]**. Proceed to share the key after it is created.
2. Guest receives the Bluetooth Key by one of these methods:
 - Clicking the URL given and follow the instructions.
 - Claiming Bluetooth Key under **[Configuration]**.
3. Guest can now use the Bluetooth Key under the Guest Bluetooth Key Section whenever he/she is within range of the lock.

Notes:

- The owner can revoke the Bluetooth Key in App.
 - Bluetooth Key must be accepted within 1 hour generation before it expires.
-

Unlocking

a

Bluetooth Unlock

1. Open your igloohome app
2. Tap on the "Bluetooth Unlock" button
3. The status indicator will flash green twice with 4 short ascending tone once unlocked.

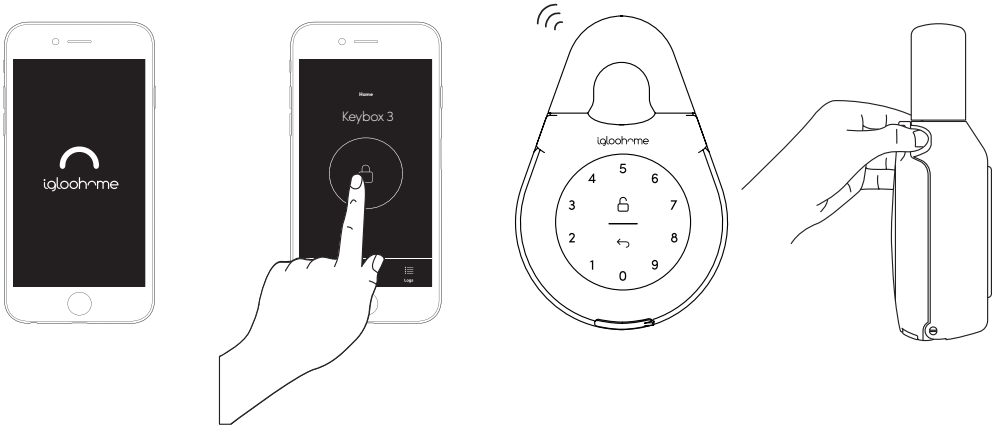

b

PIN Code

1. Press any button on the keypad to wake device up
2. Key in a valid PIN code (with or without masking pins) followed by the "Unlock Icon"
3. The status indicator will flash green twice with 4 short ascending tone once unlocked.

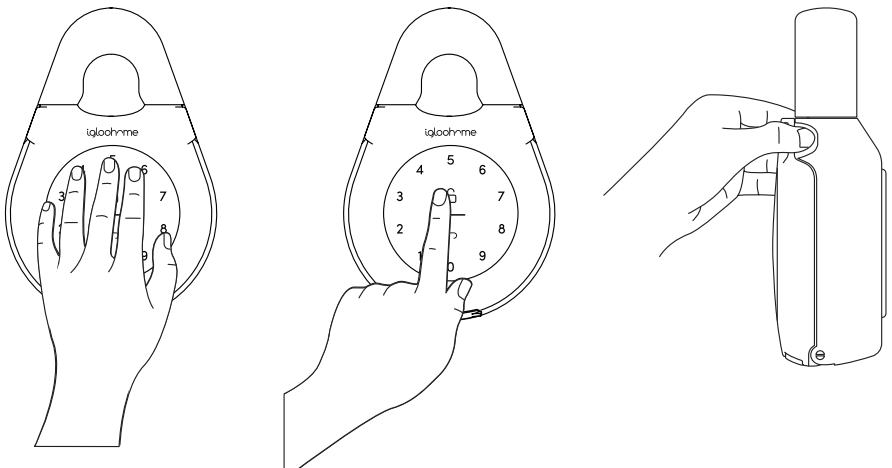

Locking

a Auto Relock

Simply close the keybox in place and Status Indicator will show green with a long beep.

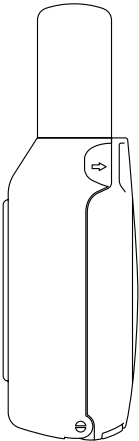
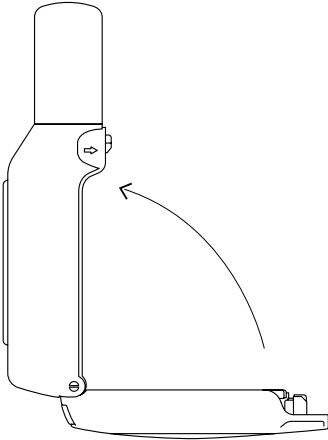

b Manual Relock

Press and hold the Unlock icon on the bottom right of the keypad for 2 seconds until the status indicator will show green with a long beep.

Note: Used when Auto Relock is "Off"

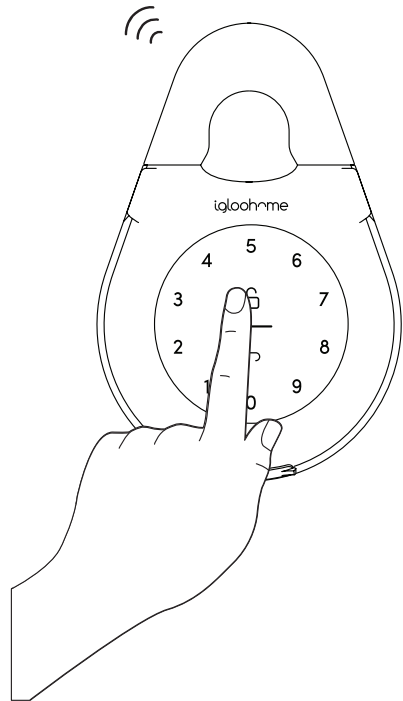

Lock Installation

a Secure Keybox on a handle or knob

1. Unlock the keybox
2. Push the shackle release to the right
3. Pull out the shackle
4. Secure on a handle or knob
5. Insert back the shackle

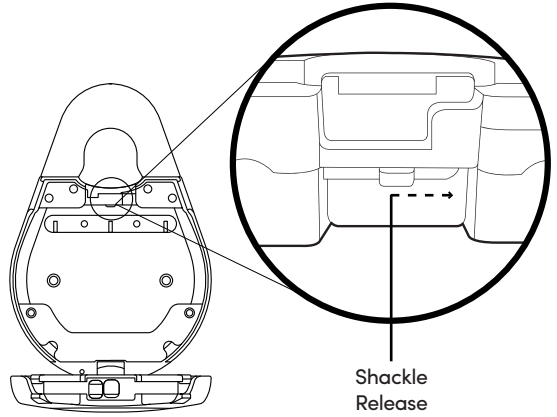
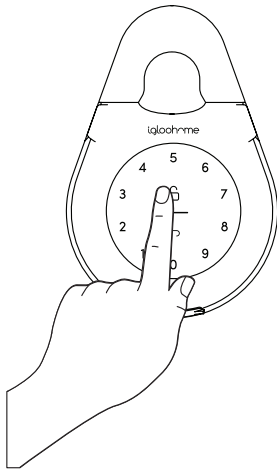

For door handles,
use Regular Shackle

For door knobs,
use Slim Shackle

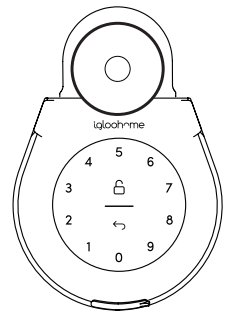
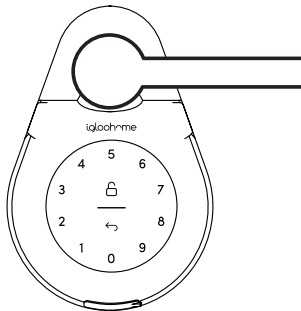
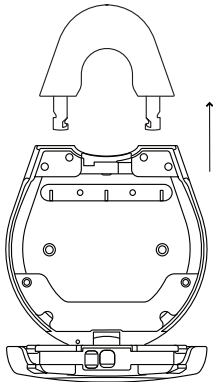

b

Mount on a surface

- 1. Unlock the keybox
- 2. Drill holes on a wall
- 3. Hammer the screw anchors into the holes
- 4. Mount the Keybox 3 on the wall with the mounting seal rings and 2 screws

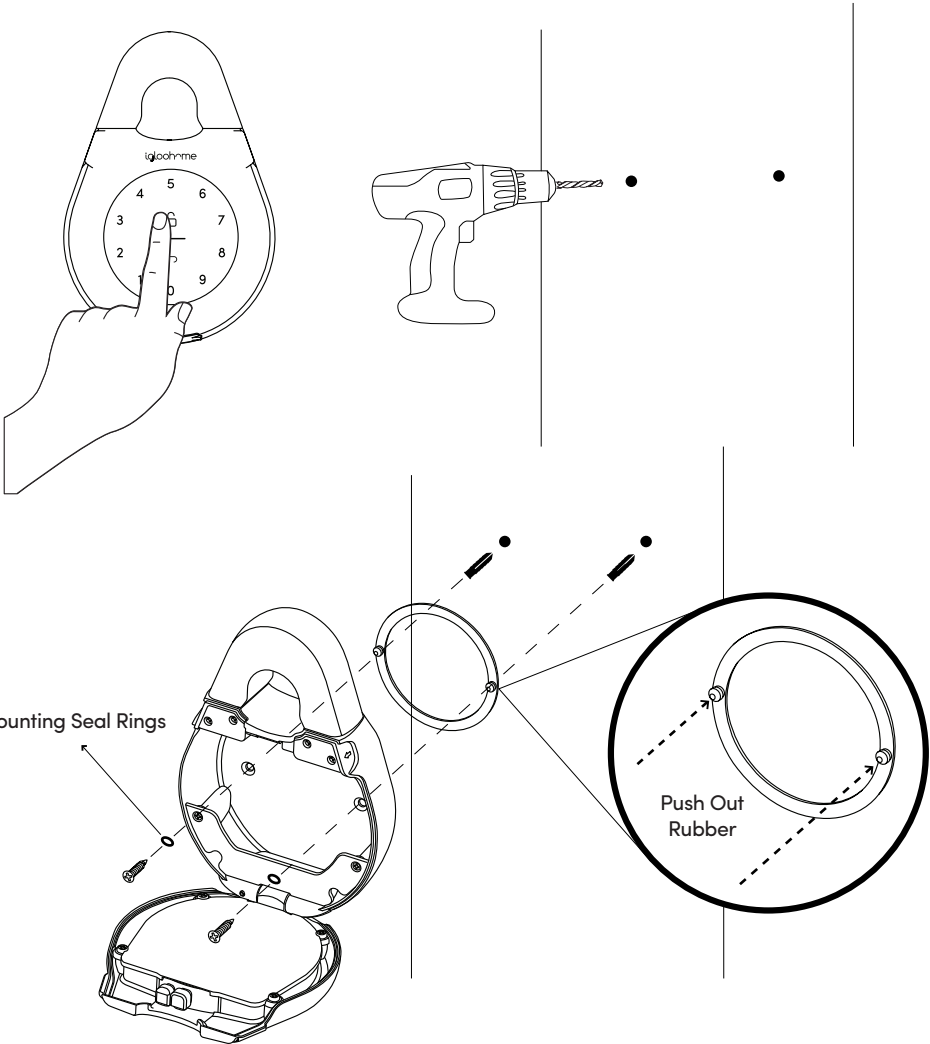

Mounting Seal Rings

Push Out Rubber

Lock Behaviour

Note: User is able to Enable and Disable Keypad Security Lockout via Bluetooth.

Keypad Security Lockout	
Triggered by	5 consecutive PIN Code attempts by default (Configurable via Bluetooth)
Disable By	After 1 / 5 / 10 Minutes or Master / Guest Bluetooth Unlock
Behaviour	Single flash White LED on keypad and Red LED on status indicator when keypad is triggered.
Duration	Please refer to table below.

Triggered	Security Alarm	Keypad Lockout
1st Time	30 Sec	1 Min
2nd Time	60 Sec	5 Min
3rd and Consecutive Time	90 Sec	10 Min

USB-C Jumpstart

1 USB-C Jumpstart Feature

1. Connect the USB-A to USB-C cable to a power bank then plug it onto the USB-C jumpstart port on the keybox.
2. While the USB-A to USB-C cable is connected to the power bank, key in PIN code on the keypad followed by  to unlock.

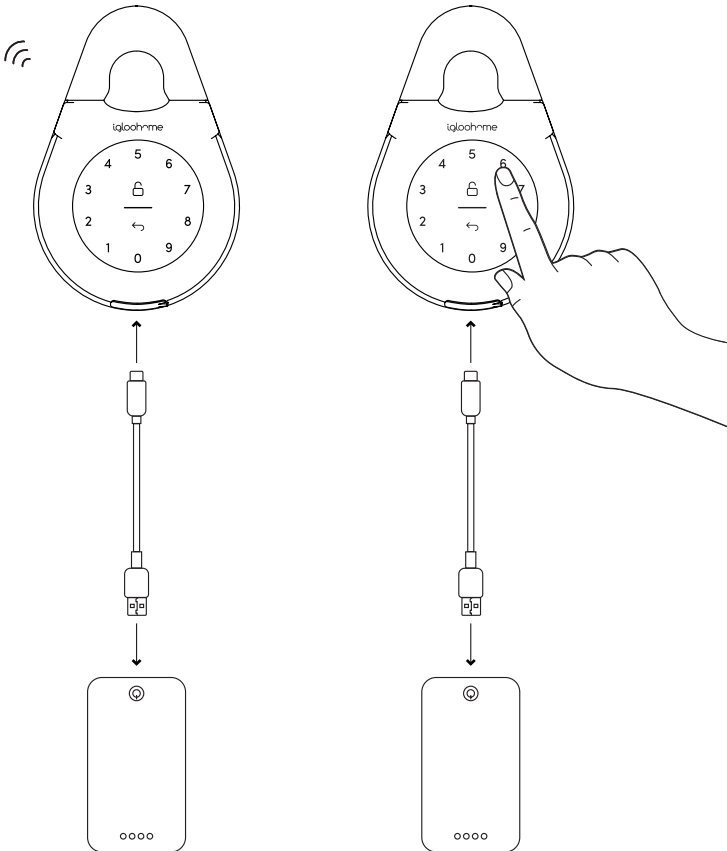

 Please unlock by entering a valid PIN code or via the app within 20 seconds after the keybox is powered up.

Audio and LED Indications

Actions	Indications
Bluetooth Connection	Status indicator flashes Blue
Successfully Unlocked	Ascending 4 fast tones after unlocked and flash Green LED 2 times
Successfully Locked	1 long beep after product is locked and Green LED for 2 seconds
Incorrect PIN	4 short beeps and flash Red 2 times
Deleted PIN	3 sets of 4 short beeps and flash Red 2 times
Obstruction Alarm	6 sets of 4 short beeps
Security Lockout Alarm	Low - High siren for 30 / 60 / 90 seconds
Security Lockout Deactivated	2 long beeps
Low Battery Alert	Descending 3 fast tones when keypad is woken up and breathing Red LED
Hard Reset / Unpair	Descending 4 slow tones
Power Start Up	2 slow beeps then 2 quick beeps

Troubleshoot

I am unable to close the keybox.

- Do an unlock via PIN code or Bluetooth and try to close the keybox again.
- Note that you might accidentally lock the keybox manually by holding the UNLOCK button for 2 seconds when the keybox is open.

I am unable to remove the battery cover screws.

- Note that the screws are designed to be retained, therefore cannot be removed.
- Please loosen the screws to remove the battery cover.

The keybox keypad flashes white and LED indicator flashes red when I activate the keypad.

- Keypad Security Lockout is triggered on the Keybox.
- Please refer to page 15.

I tried to use USB-C to jumpstart the lock but unable to.

- Please ensure USB-C connector is connected to the USB-C slot securely while unlocking it with PIN code or Bluetooth.
- Please unlock within 20 seconds.
- Please ensure that the Power Bank has sufficient power.

The lock is not responding at all.

- The Keybox's battery is flat.
- Use an USB-A to USB-C cable connected to a power bank to jumpstart the lock and unlock the keybox to replace the batteries.
- Please unlock within 20 seconds.
- Refer to page 8 to know how to replace batteries.

I closed the Keybox but it did not relock automatically.

- Make sure Auto Relock is ON via the igloohome mobile app.
- If Auto Relock is ON and the keybox is still not working, try to lock the keybox manually by holding the UNLOCK button for 2 seconds.

I tried to unlock the Keybox but the keypad went off and came back on with 2 slow and 2 quick beeps.

- The Keybox is low in battery.
- Use an USB-A to USB-C cable connected to a power bank to jumpstart the lock and unlock the Keybox to replace the batteries.
- Refer to page 8 to know how to replace batteries.

I can't scan the QR sticker as it is worned out.

- Use the spare QR sticker that is provided in the Keybox box.

I have generated my PINs from the app but it cannot work.

- Do a Bluetooth Unlock or sync and try again.
- Make sure that the generated PIN codes are activated within the activation period before it expired.

For enquiries go to:
igloohome.co/support