



B1GCC0AN0B EOX5 Februar 2018

A



Included accessories

1 x combination grid, 1 x universal pan

Optional accessories

Z11AB15A0 : Baking tray, non-stick ceramic coated , Z11AU15A0 : Universal pan, non-stick ceramic coated , Z11CB10E0 : Baking tray, grey enamelled , Z11CL15E0 : Lid for professional pan, enamelled grey , Z11CN15E0 : Professional pan, grey enamelled , Z11CR10X0 : Baking and roasting grid (standard) , Z11CU10E0 : Multipurpose pan, grey enamelled , Z11GT10X3 : Glass roasting dish, 5,4l , Z11GU20X0 : Glasspan , Z11TE25X0 : 2 level telescopic shelf rails , Z11TF25X0 : 2 level telescopic shelf rails,full ext , Z11TF36X0 : 3 level telescopic rails, full ext , Z11TI15X0 : Cliprails , Z11TJ25X0 : 2 level telescopic rails incl 1VarioClip , Z11TJ35X0 : 3 level telescopic rails incl 1VarioClip , Z12CN10A0 : Professional pan, anthracite enamelled , Z12CQ10A0 : Grill tray, anthracite enamelled , Z1352X0 : Pizza pan, grey enamelled , Z13CV05S0 : Cover Strip , Z19DD10X0 : Steam set for ovens , Z9220W0 : Conversion cabinet

Features

Technical Data

Product color : Stainless steel
 Construction type : Built-in
 Integrated Cleaning system : No
 Required cutout size (HxWxD) (mm) : 585-595 x 560-568 x 550
 Overall appliance dimensions (HxWxD) (mm) : 595 x 594 x 548
 Product packaging dimensions (HxWxD) (mm) : 675 x 690 x 660
 Control Panel Material : Stainless steel
 Door Material - primary cavity : Glass
 Net weight (kg) : 31.639
 Usable volume of cavity (l) : 71
 Cooking mode : Conventional heat, Full width broil, Hot Air, Hot air broiling, Hotair gentle
 Primary cavity material : Other
 Number of interior lights : 1
 Approval certificates : CE, VDE
 Power cord length (cm) : 120
 Interior Lights - primary cavity : 1
 Pull-out system : Accessory
 Timer settings : Alarm, Off, On
 Included accessories : 1 x combination grid, 1 x universal pan
 Broil Element Wattages primary cavity (W) : 2700
 Convection Element Wattages primary cavity (W) : 1600
 Energy efficiency class (2010/30/EC) : A
 Energy consumption per cycle conventional (2010/30/EC) : 0.97
 Energy consumption per cycle forced air convection (2010/30/EC) : 0.81
 Energy efficiency index (2010/30/EC) : 95.3
 Watts (W) : 2990
 Current (A) : 13
 Volts (V) : 220-240
 Frequency (Hz) : 50; 60
 Plug type : no plug
 Product color : Stainless steel
 Energy source : Electric
 Approval certificates : CE, VDE
 Required cutout size (HxWxD) (in) : x x
 Product packaging dimensions (HxWxD) (in) : 26.57 x 25.98 x 27.16
 Net weight (lbs) : 70.000
 Gross weight (lbs) : 75
 Power cord length (cm) : 120
 Net weight (kg) : 31.639
 Gross weight (kg) : 34.0



4 242004 234036

Line drawings

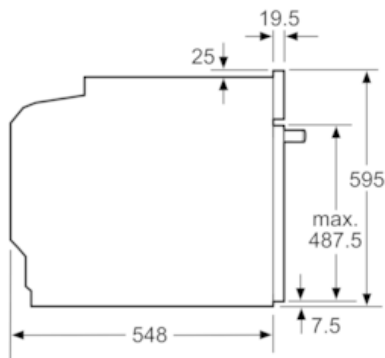

measurements in mm

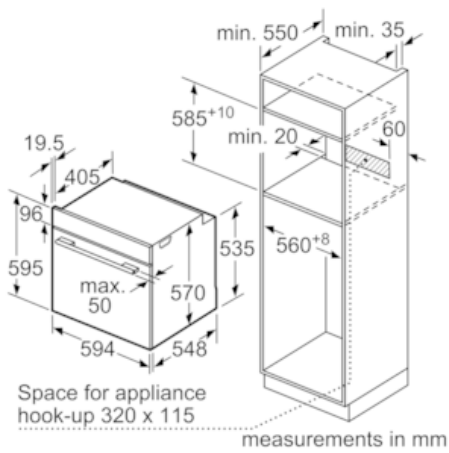

measurements in mm

Installation with a cooktop.

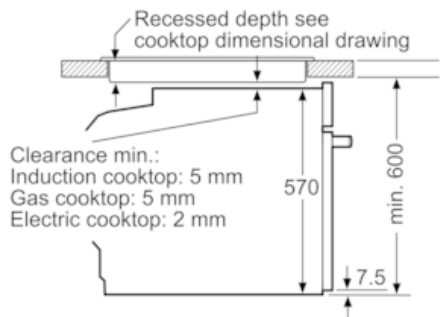

Clearance min.:
 Induction cooktop: 5 mm
 Gas cooktop: 5 mm
 Electric cooktop: 2 mm

measurements in mm