

PRODUCT FICHE



Washing machine
741590
W4096R.W.UK/1
USP :

Product group	Washing Machine
Image	
Auto	Yes
Time program	Yes
Heavy	Yes
Wool/hand wash	Wool/hand program
Rinse	Yes
Spin	Yes
Drain	Yes
Drum cleaning	Yes
High water level	Yes
Extra rinsing	Yes
Delayed Start	Yes
Spin speed	1600 rpm
Quattro Construction™ - vibration-free spinning	Yes
Remaining time indication	Yes
Unbalance detection - protects the washer against harmful vibrations.	Yes
Anti Block™ - Self cleaning drain pump.	Yes
AquaStop	Pex inlet hose

Basic information :

Brand	ASKO
Product name / Family	Washing machine
Commercial code	W4096R.W.UK/1
Internal article number	741590
EAN code	3838782659096
Construction type	Free-standing
Removable top	N/A
Cover door / Double door	Door cover
Loading type	Front loader
Door hinge	Left
Color / Material panel	Plastics
Color / Material body	Galvanized and painted steel
Connection Rating	2200 W
Current	13,0
Voltage	220-240 V
Frequency	50 Hz
Marks of conformity	CE,SIQ1
Length of electrical supply cord	210 cm
Plug type	GB
Height with worktop	850 mm
Net weight	77,5 Kg
Gross weight	80,7 Kg
Door opening diameter	310 mm
Control mode	Electronic
Adjustable feet	Yes - all
Wheels	No
Maximum adaptability of feet	10 mm
Main colour of product	BK070; White
Product group	Washing machine
Installation type	Free-standing
Basic color of product	N/A
Width	595 mm
Height	850 mm
Depth	585 mm
Width of packed product	640 mm
Height of packed product	920 mm
Depth of packed product	661 mm

Features :

Spin speed options	Variable
--------------------	----------

Skip spin	Yes
Foam control	Yes
Balance control	Yes
Water protection system	Yes
Separate temperature control options	Continuous
Cold wash option	Yes
Digital countdown indicator	No
Start delay options	Continuous
Pre-wash	Yes
Quick wash	No
Wool program	No
Delicates / Silk	No
Water plus	Yes
Door opening	Handle
Tub material	Stainless steel
Drum volume	60 l
Drum material	Stainless steel
Hot & cold water intake	No
Automatic programs	Yes
Upgradeable software	No
Short description of the product	WM75.169B1 - W4096R.W.UK/1 - RL_LOGI
Wireless capability	No
Interior light	No

Energy label information / Performance :

Energy efficiency class	A
Spin drying performance class	A
Maximum spin speed (rpm)	1600 rpm
Rated capacity (kg)	9,0 Kg
Energy consumption in stand-by mode (W)	0,3 W
Energy consumption Off mode (W)	0,3 W
Built in	No
Energy label applicable	Yes
ECO label	No
Airborne acoustical noise emission class (a) (spinning phase)	B
Airborne acoustical noise emissions in the spinning phase (dB(A) re 1 pW)	76 dB re 1 pW
Rinsing effectiveness (g/kg)	4,3 g/kg
EEl	51,8
Energy consumption in kWh per cycle, based on the eco 40-60 programme. Actual energy consumption will depend on how the appliance is used	0,49 kWh/kg
Water consumption in litre per cycle, based on the eco 40-60 programme. Actual water consumption will depend on how the appliance is used and on the hardness of the water.	49 l/cycle
Spin speed (rpm) [Half]	1600 rpm
Spin speed (rpm) [Quarter]	1600 rpm
Spin speed (rpm) [Rated capacity]	1600 rpm
Remaining moisture content (%) [Half]	44 %
Remaining moisture content (%) [Quarter]	44 %
Remaining moisture content (%) [Rated capacity]	44 %
Maximum temperature inside the treated textile (°C) [Half]	20 °C
Maximum temperature inside the treated textile (°C) [Quarter]	20 °C
Maximum temperature inside the treated textile (°C) [Rated capacity]	38 °C
Programme duration (h:min) [Half]	171
Programme duration (h:min) [Quarter]	171
Programme duration (h:min) [Rated capacity]	210
Energy consumption in delay start (W)	3,44 W
Energy Smart appliance, able to optimise consumption pattern (2017/1369/EU)	No

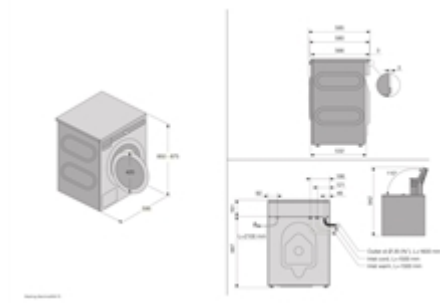

The eco 40 60 program is a program for washing normally soiled cotton laundry and refers to the data on the energy label and product information sheet and is the most efficient regarding energy and water consumption.