

**Series 8, Built-in microwave oven, 60
x 45 cm, Black
CEG732XB1B**

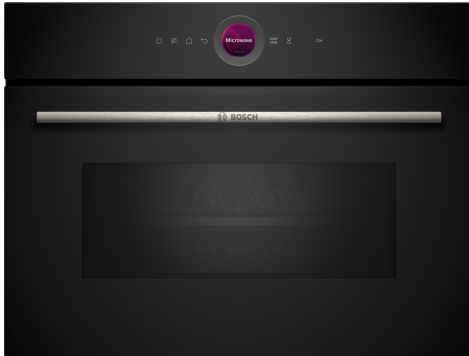

**The compact microwave 45cm. Inverter
Technology: constant microwave power
for heating food gradually. Microwave
Boost Function: quick and easy warming.**

- **Digital Control Ring:** simple and intuitive oven control.
- **TFT Touch Display:** intuitive control with the Digital Control Ring and TFT touchscreen.
- **AutoPilot 10:** every dish is a perfect success thanks to 10 pre-set automatic programmes.
- **White LCD display control:** easy-to-use thanks to direct access to additional functions, temperature recommendation and temperature indication.
- **Cleaning Assistance:** less cleaning effort

Technical Data

Type of micro-wave oven: MW only
 Type of control:Electronic
 Dimensions: 455 x 594 x 564 mm
 Cavity dimensions: 245.0 x 430 x 350 mm
 Length of electrical supply cord: 150.0 cm
 Net weight: 27.0 kg
 Gross weight: 30.0 kg
 EAN code: 4242005322725
 Maximum micro-wave power: 1000 W
 Connection rating: 3100 W
 Fuse protection: 16 A
 Voltage: 220-240 V
 Frequency: 50 Hz
 Plug type:fixed connection
 Included accessories: 1 x Plug-in grid



Series 8, Built-in microwave oven, 60 x 45 cm, Black CEG732XB1B

**The compact microwave 45cm. Inverter
Technology: constant microwave power
for heating food gradually. Microwave
Boost Function: quick and easy warming.**

Features

- Maximum microwave power level: 1000 W and the following options 1000 W, 180 W, 360 W, 600 W, 90 W
- Intelligent microwave inverter technology: For optimised results maximum output power will be regulated to 600 W when used in longer operation for gentler cooking.
- 1.9 KW grill function
- Grill and microwave power levels 90 W, 180 W, 360 W, 600 W combinable

Design

- stainless steel, Glass base cavity with Glass base, stainless steel
- Touch controls
- Touch key operation

Cleaning

- hydrolyse program

Programmes/functions

- Electronic clock timer
- User-friendly electronics: extremely
- easy and comfortable operation
- AutoPilot, 10
- 3 defrost and 4 cooking programmes in microwave function
- Quick Start Button: one tap to maximum microwave power for 30 seconds
- LED light
- Cavity volume: 36 l
- Drop down door, SoftClose

Accessories

- 1 x Plug-in grid

Features

- Automatic safety switch off
- Start button Door contact switch
- Integral cooling fan

Technical information

- Power cord length 150 cm Cable length
- Total connected load electric: 3.1 KW
- Nominal voltage: 220 - 240 V
- installation in tall housing

Performance/technical information

- Appliance dimension (hxwxh): 455 mm x 594 mm x 564 mm
- Niche dimension (hxwxh): 450 mm - 450 mm x 560 mm - 560 mm x 550 mm
- Please refer to the dimensions provided in the installation manual

**Series 8, Built-in microwave oven, 60
x 45 cm, Black
CEG732XB1B**

Measurements in mm

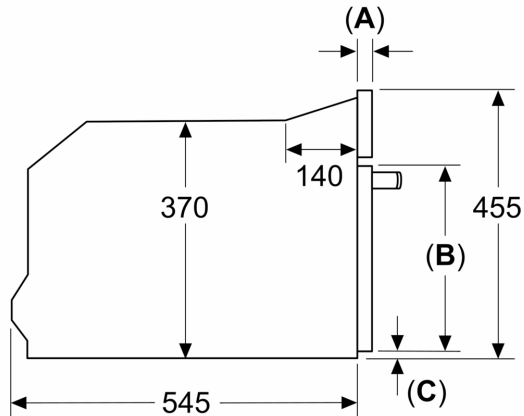

A: 19.5 mm
B: ≤ 347.5 mm
C: 7.5 mm

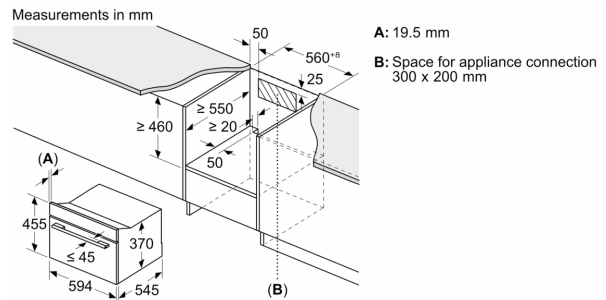

A: 19.5 mm
**B: Space for appliance connection
300 x 200 mm**

Measurements in mm

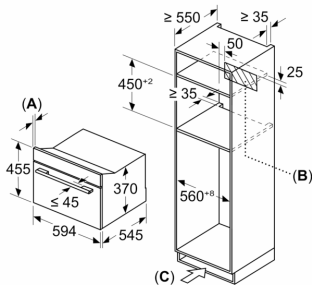

A: 19.5 mm
**B: Space for appliance connection
300 x 200 mm**
**C: Ventilation space in the base ≥
50 cm²**