

## iQ700, Built-in microwave oven, Black BF722L1B1B



The microwave with touchControl for easy control and direct selection of heating modes.

- ✓ TFT-Touchdisplay – Touch navigation for intuitive operation.
- ✓ For fast cleaning dirt is softened beforehand by vaporizing soapy water. It can then be removed more easily – humidClean program.
- ✓ Automatic programs ensure excellent results - cookControl7.
- ✓ 900 Watts maximum: ideal for heating liquids
- ✓ The side-opening hinged door: ideal for elevated installation.

### Features

#### Technical Data

Additional functions: ..... Microwave only  
 Control panel: ..... Electronic  
 Dimensions: ..... 382 x 594 x 318 mm  
 Cavity dimensions: ..... 230 x 350 x 270 mm  
 Length of electrical supply cord: ..... 175.0 cm  
 Weight: ..... 17.1 kg  
 Gross weight: ..... 18.9 kg  
 EAN code: ..... 4242003906538  
 Max. microwave power: ..... 900 W  
 Connection Rating: ..... 1220 W  
 Fuse protection: ..... 10 A  
 Nominal power: ..... 220-240 V  
 Frequency: ..... 50; 60 Hz  
 Plug type: ..... GB plug



### Optional accessories

HZ6UCC0 Cookbook  
 HZG9AS00S Adapter

# iQ700, Built-in microwave oven, Black BF722L1B1B

## Features

### Features

- Maximum microwave power level: 900 W and the following options 180 W, 360 W, 600 W, 90 W, 900 W
- Intelligent microwave inverter technology: For optimised results maximum output power will be regulated to 600 W when used in longer operation for gentler cooking.
- Cavity volume: 21 l

### Design

- stainless steel, Stainless steel cavity with glass base cavity with Stainless steel cavity with glass base, stainless steel

### Cleaning

- hydrolyse program

### Programmes/functions

- Electronic oven clock timer
- Touch control
- User-friendly electronics: extremely
- easy and comfortable operation
- cookControl, 7
- 3 defrost and 4 cooking programmes in microwave function
- yes: one tap to maximum microwave power for 30 seconds
- LED light
- Left hinged door
- Electronic door opening button
- Touch key operation

### Features

- Start button
- Door contact switch
- Integral cooling fan

### Technical information

- Total connected load electric: 1.22 KW
- Nominal voltage: 220 - 240 V
- Installation in 60 cm wide wall unit, Installation in tall housing

### Performance/technical information

- Appliance dimension (hxwxd): 382 mm x 594 mm x 318 mm
- Niche dimension (hxwxd): 362 mm - 382 mm x 560 mm - 568 mm x 300 mm
- Please refer to the dimensions provided in the installation manual

**iQ700, Built-in microwave oven,  
Black  
BF722L1B1B**

Dimensioned drawings

Measurements in mm

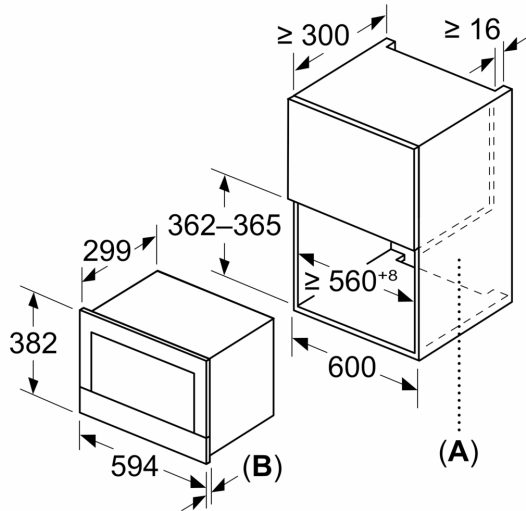

**A:** Back wall open  
**B:** 19.5 mm

Measurements in mm

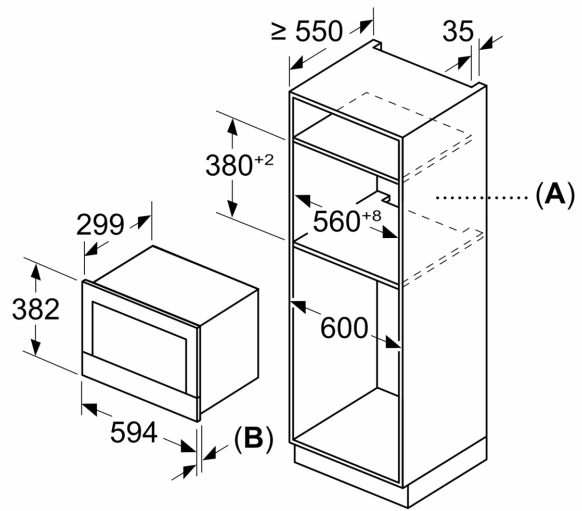

**A:** Back wall open  
**B:** 19.5 mm

measurements in mm

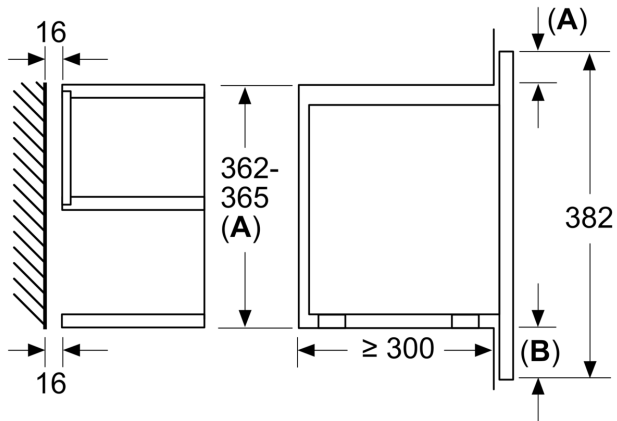

**A:** Overhang at top:  
Recess 362: 6 mm  
Recess 365: 3 mm  
**B:** Overhang at bottom: 14 mm