

## iQ500, Built-under freezer, 82 x 59.8 cm, flat hinge GU15DAFF0G



undercounter freezer with 3 handy transparent freezer drawers and superFreezing for freezing foods faster.

- ✓ superFreezing – Quick-freeze even large amounts of food.
- ✓ 3 transparent freezer drawers provide plenty of space and an optimum view.

### Features

#### Technical Data

Energy Efficiency Class: F  
 Average annual energy consumption in kilowatt hour per year (kWh/a): 224 kWh/a  
 Sum of volume of frozen compartments: 106 l  
 Airborne acoustical noise emissions : 38 dB(A) re 1 pW  
 Airborne acoustical noise emission class: C  
 Thermometer freeze section: Analog  
 Light: No  
 Product category: Upright freezer  
 Construction type: Built-in  
 Door panel options: Possible but accessory  
 Frost free system: No  
 Height of the appliance: 820 mm  
 Width of the appliance: 598 mm  
 Depth of the product: 550 mm  
 Dimensions of the packed product (HxWxD): 890 x 620 x 670 mm  
 Net weight: 36.8 kg  
 Gross weight: 39.7 kg  
 Connection rating: 90 W  
 Fuse protection: 13 A  
 Frequency: 50 Hz  
 Length of electrical supply cord: 230.0 cm  
 Door hinge: Right reversible  
 Defrost process: manual  
 Warning signal / malfunction: visual and audible  
 Door lock: No  
 Number of drawers/baskets (Stck): 3  
 Number of freezing flaps (Stck): 0  
 EAN code: 4242003844939  
 Brand: Siemens  
 Product name / Commercial code: GU15DAFF0G  
 Product category: Upright freezer  
 Included accessories: 1 x ice cube tray

### Included accessories

1 x ice cube tray



**iQ500, Built-under freezer, 82 x 59.8  
cm, flat hinge  
GU15DAFF0G**

#### Features

**Included accessories**

- KF10ZAX0, KU20ZSX0

**Key features - Freezer section**

- Temperature indicator on inside of door
- Dial temperature control
- superFreeze function with automatic deactivation
- Freezer malfunction warning signal: optical, acoustical
- Ventilation through plinth
- Variable plinth adaption
- Height adjustable feet in the front
- 3 freezer drawers
- Right hinged door, reversible door
- Dimensions: 82 cm H x 59.8 cm W x 54.8 cm D
- Connection value 90 W
- 220 - 240 V
- GU15DAFF0G

**Dimension and installation**

- Convenience and Safety

**Performance and Consumption**

- EU19\_EEK\_D: F
- Total Volume : 106 l
- Net Fridge Volume : 0 l
- Net Freezer Volume : 106 l
- Freezing capacity 24h : 7.4 kg
- Annual Energy Consumption: 224 kWh/a
- Climate Class: SN-T
- Noise Level : 38 dB , EU19\_Noise emission class\_D: C
- Temperature rise time : EU19\_Temperature rise time\_D: 10 H

**iQ500, Built-under freezer, 82 x 59.8 cm, flat hinge  
GU15DAFF0G**

Dimensioned drawings

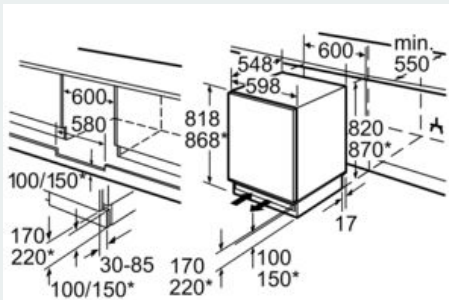

\* variable base/substructure height

Space for electrical connection next to the appliance on the left or right-hand side.  
Ventilation space in the base.

measurements in mm

measurements in mm

Recommended gap dimensions for flat hinges

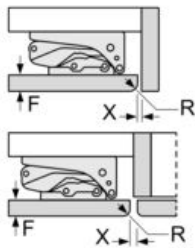

	F	R	X
16-19	0-3	2.5	
	20	0-1	3
21	2-3	2.5	
	21	0-1	3
22	2-3	2.5	
	22	0	4
	22	1	3.5
	2-3	3	

The gap dimensions recommended in the table must be adhered to in order to ensure that appliance doors do not collide with anything when they are opened, and to avoid causing damage to kitchen units.

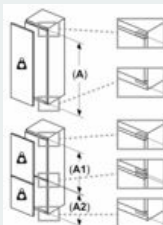

Maximal permissible weight of the unit fronts

Fitted unit fronts that exceed the permissible weight may cause damage and result in functional impairment of the hinges.

Δ Weight

A: Appliance door height including hinges in mm

B: Undamped hinge, unit front in kg

C: Damped hinge, unit front in kg

D: Additional possible load in kg with heavy load kit

A	B	C	D
1500-1750	22	22	
720-1400	19	19	
A1	15	19	B+5 / C+5
A2	15	19	