

iQ500, Built-in fridge-freezer with freezer at bottom, 193.5 x 70.8 cm, soft close flat hinge KB96NADD0G



Optional accessories

KSZGGM00 Butter box

Built-in fridge freezer with 45 percent extra space and hyperFresh <0°C>: ideal storage conditions for all your food and XXL capacity to shop in bulk.

- ✓ bottleRack – Store your bottles safely and within easy reach.
- ✓ superCooling – Reduces the temperature for a set time, to quickly cool down fresh food items.
- ✓ safetyGlass shelves – Extra strong and easy to clean.

Features

Technical Data

Energy Efficiency Class: D
 Average annual energy consumption in kilowatt hour per year (kWh/a): 204 kWh/annum
 Sum of volume of frozen compartments: 98 l
 Sum of volume of chill compartments: 284 l
 Airborne acoustical noise emissions : 33 dB(A) re 1 pW
 Airborne acoustical noise emission class: B
 Design: Built-in
 Door panel options: Not possible
 Height: 1935 mm
 Width of the appliance: 708 mm
 Dimensions: 548 mm
 Min. required niche size for installation (HxWxD): 1940 x 710 x 560 mm
 Weight: 73.2 kg
 Fuse protection: 10 A
 Door opening: Right reversible
 Nominal power: 220-240 V
 Frequency: 50 Hz
 Length of electrical supply cord: 230.0 cm
 Number of compressors: 1
 Number of independent cooling systems: 2
 Interior ventilator: Yes
 Reversible Door Hinge: Yes
 Number of Adjustable Shelves in fridge compartment (Stck): 4
 Shelves for Bottles: Yes
 Frost free system: Freezer
 Installation type: not available



iQ500, Built-in fridge-freezer with freezer at bottom, 193.5 x 70.8 cm, soft close flat hinge KB96NADD0G

Features

Design features

- noFrost freezer, Built-in fridge freezer
- Right hinged door, door reversible
- Fixed hinge, softClosing door system - dampens door movement, for smooth and effortless closure
- Height adjustable front feet
- LED fridge light with Soft Start in fridge section
- Electronic control (2 LED chains)

Functions

- Automatic defrost in fridge section
- NO_FROST_NEU_BL, never have to defrost ever again
- Twin evaporators allows independent temperature control and ensures there is no transference of humidity between the fridge and freezer cavity.
- Super Cooling: automatic deactivation
- acoustic alarm, Optical and acoustical door open warning system, acoustic for Fridge and Freeze
- Home Connect: iService Remote, Remote Monitoring and Control with Wi-Fi connectivity

Food freshness system

- 1 hyperFresh box with integrated humidity control

Key features - Fridge section

- 5 safety glass shelves of which 4 are height adjustable
- Bottle rack
- Door shelves in fridge door: 1 large and 2 small.

Key features - Freezer section

- 3 freezer drawers

Additional features

- 3 x egg tray, 2 x ice cube tray

Performance and Consumption

- Climate Class: SN-T
- Total Volume : 381 l
- Net Fridge Volume : 284 l
- Net Freezer Volume : 98 l
- Annual Energy Consumption: 204 kWh/a
- Noise Level : 33 dB , EU19_Noise emission class_D: B
- Temperature rise time : EU19_Temperature rise time_D: 13 H
- Freezing capacity 24h : 10 kg
- 220 - 240 V
- EU19_EEK_D: D
- EU19_Fast freezer facility_D
- Based on the results of the standard 24-hour test. Actual consumption depends on usage/position of the appliance.

Dimension and installation

- Dimensions: 193.5 cm H x 70.8 cm W x 54.8 cm D

- Niche Dimensions: 194 cm H x 71 cm W x 56 cm D
- Length of power cord:230 cm

Country Specific Options

**iQ500, Built-in fridge-freezer with
freezer at bottom, 193.5 x 70.8
cm, soft close flat hinge
KB96NADD0G**

Dimensioned drawings

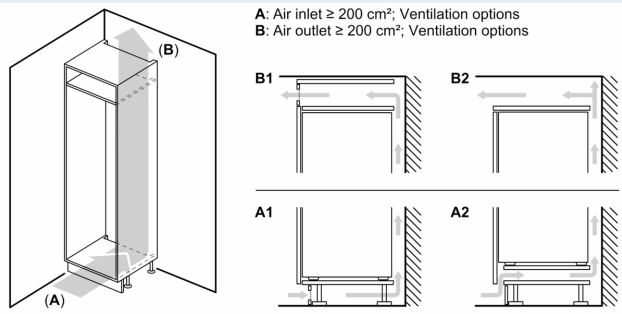

Measurements in mm

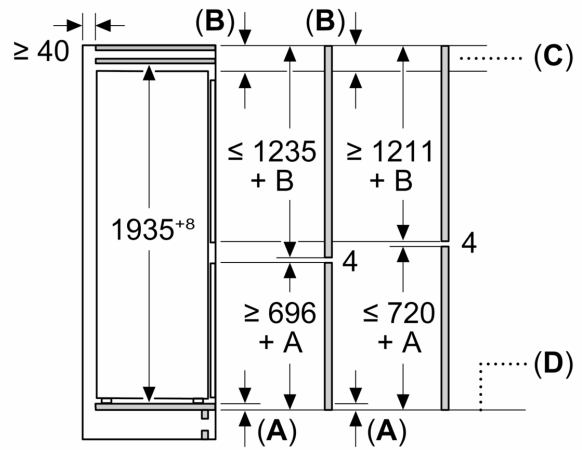

C: Front panel overhang

D: Lower edge of front panel

Measurements in mm

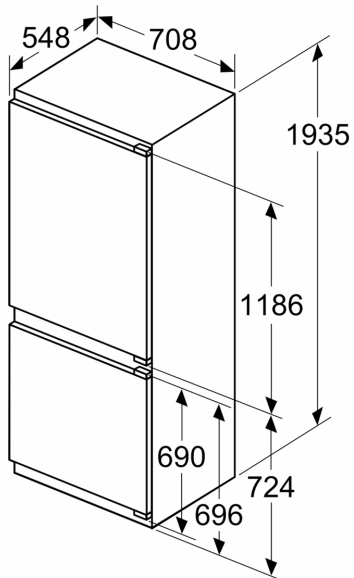

Measurements in mm

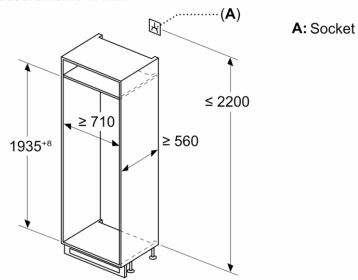

Dimensioned drawings

Maximal permissible weight of the unit fronts

Fitted unit fronts that exceed the permissible weight may cause damage and result in functional impairment of the hinges

Δ Weight

A1	20 kg
A2	19 kg

measurements in mm

Recommended gap dimensions for flat hinges

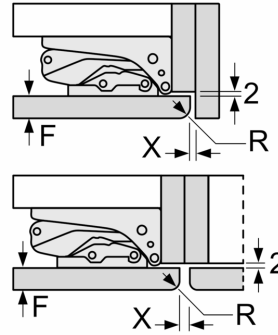

F	R	X
16-19	0-3	2.5
20	0-1	3
	2-3	2.5
21	0-1	3
	2-3	2.5
22	0	4
	1	3.5
	2-3	3

The gap dimensions recommended in the table must be adhered to in order to ensure that appliance doors do not collide with anything when they are opened, and to avoid causing damage to kitchen units.