

iQ500, Washing machine, front loader, 1400 rpm WN44G290GB



smartFinish washer-dryer with speedPack saves time and reduces ironing effort.

- ✓ speedPack – Speed up your programmes or wash and dry in just 60 minutes.
- ✓ smartFinish – Smooth away creases to cut down on ironing.
- ✓ Outdoor/waterproofing programme – Protects your waterproof textiles.
- ✓ Wash and dry in only 60 minutes with Wash & Dry 60

Features

Technical Data

Energy Efficiency Class Wash/Dry cycle(Regulation): E
 Energy Efficiency Class Eco 40-60 programme (Regulation): C
 Weighted energy consumption in kWh per 100 full Wash/Dry cycles:
372 kWh
 Weighted energy consumption in kWh per 100 washing cycles of
 eco 40-60 programme:64 kWh
 Maximum capacity in kg in a Wash/Dry cycle: 6.0
 Maximum capacity in kg in a wash cycle:9.0
 The water consumption of the full wash and dry cycle in liters per
 cycle: 84 l
 The water consumption of the eco programme in liters per cycle:
 41 l
 Duration of the full wash and dry cycle in hours and mins at rated
 capacity:7:45 h
 Duration of eco 40-60 programme in hours and mins at rated
 capacity: 3:45 h
 Spin-drying efficiency class of eco 40-60 programme: B
 Airborne acoustical noise emissions : 69 dB(A) re 1 pW
 Airborne acoustical noise emission class:A
 Design: Freestanding
 Removable work top:No
 Door opening:Left
 Length of electrical supply cord: 210.0 cm
 Height of removable worktop: -12 mm
 Dimensions of the product: 848 x 598 x 590 mm
 Weight: 81.4 kg
 Drum volume: 65 l
 EAN code:4242003867822



Optional accessories

| | |
|----------|--|
| WX975600 | Floor securing component |
| WZ10131 | Extension for cold water inlet /Aquastop |
| WZWP20W | Platform with pull-out, washer, cubic |

iQ500, Washing machine, front loader, 1400 rpm WN44G290GB

Features

Performance

- Energy Efficiency Class Wash and Dry¹: E
- Energy Efficiency Class Washing²: C
- Energy³ / Water⁴ Wash and Dry: 372 kWh / 84 litres
- Energy⁵ / Water⁶ Washing: 64 kWh / 41 litres
- Load capacity Wash and Dry / Washing: 1 - 6 kg / 1 - 9 kg
- Programme duration⁷ Wash and Dry / Washing: 7:45 h:min / 3:45 h:min
- Spin drying efficiency class: EU19_spin efficiency class: B
- Spin speed^{**}: 400 - 1400 rpm
- Noise level: 69 dB (A) re 1 pW
- Noise efficiency class: A

Programmes/functions

- Standard programmes for washing: cottons, easy-care, delicates/silk, wool/handwash
- Special programmes washing: rapid 15 minute quick wash, mixed fabrics, textile guard re-proofing programme, drain / spin, single rinse
- Most common washing programmes can be used as solo-drying programme or as washing and drying in one go programme
- Options washing: less ironing, Spin speed selection, auto stain (16 options), Start / Pause, Temperature selection, prewash
- Standard programmes for drying: cottons, easy-care
- Special programmes drying: Refresh, Intensive dry, Woollens program, Low heat drying, Wash & Dry 60'
- Drying options for most wash programmes
- autoDry function, and time selection options
- Options drying: Drying aim

Key features

- Automatic Stain removal - 4 stain removal options at the touch of a button
- varioSpeed: Up to 65% reduced washing cycle ***
- iQ Drive: innovative motor technology delivering energy efficiency, speed and durability
- antiVibration Design - for more stability and quietness
- Sound insulation by additional noise reduction material
- Reload Function: Stop the washing machine to add any forgotten items of laundry to the drum.

Additional features

- Large LED-Display for programme status indication, max. spin speed, remaining time and 24 h end time delay and load recommendation
- waveDrum: for highly effective and extremely gentle laundry care
- drum interior light
- Foam detection system
- Electronic child safety package
- Out of balance load adjustment
- Detergent dispensing: easy clean
- Divider for Liquid Detergent

- Acoustic signals: Buzzer
- Aqua Protection
- Maintenance free condenser: automatic fluff removal

Technical Information

- Slide-under installation
- Large silver-black door with 165° opening
- Dimensions (H x W): 84.8 cm x 59.8 cm
- Appliance depth: 59.0 cm
- Appliance depth incl. door: 63.5 cm
- Appliance depth with open door: 107.2 cm

^{1 2} Scale of Energy Efficiency Classes from A to G

³ Energy consumption in kWh per 100 complete cycles (in Eco 40-60 programme)

⁴ Water consumption in litres per complete cycle (in Eco 40-60 programme)

⁵ Energy consumption in kWh per 100 washing cycles (in Eco 40-60 programme)

⁶ Weighted water consumption in litres per washing cycle (in Eco 40-60 programme)

⁷ Duration of Eco 40-60 programme, Wash and Dry cycle / Wash only cycle

** Values are rounded.

*** Comparison between the program duration of Easy-care 40°C and the program duration of Easy-care 40°C + activated varioSpeed option

iQ500, Washing machine, front loader, 1400 rpm
WN44G290GB

Dimensioned drawings

measurements in mm

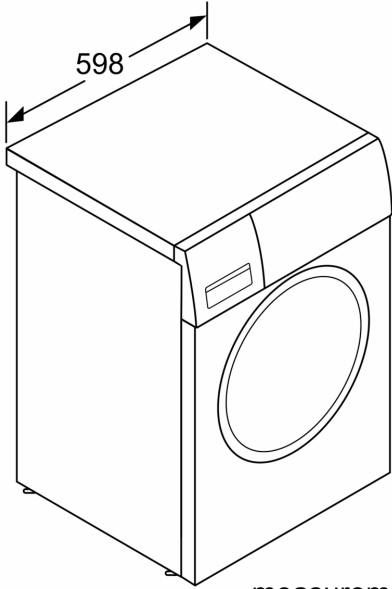
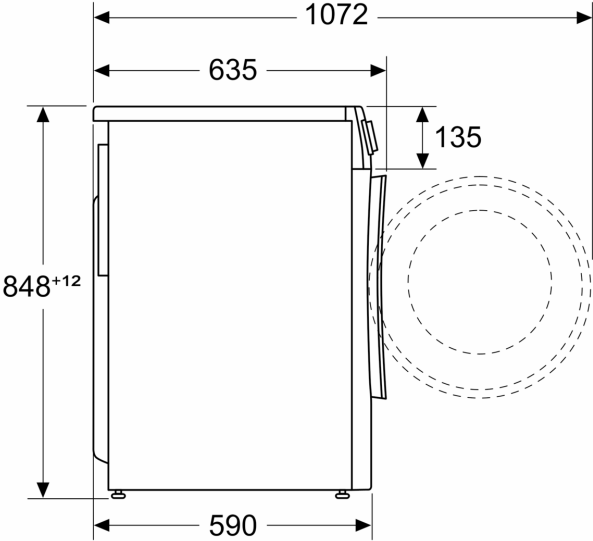

measurements in mm